

WORKING PAPER

PERIODIC BEHAVIOR OF AN AGE-DISTRIBUTED POPULATION OF TREES

*M. Ya. Antonovski
M. D. Korzukhin
V. K. Matskiavichus*

July 1989
WP-89-39

**PERIODIC BEHAVIOR OF AN
AGE-DISTRIBUTED POPULATION
OF TREES**

M. Ya. Antonovski
M. D. Korzukhin
V. K. Matskiavichus

July 1989
WP-89-39

Working Papers are interim reports on work of the International Institute for Applied Systems Analysis and have received only limited review. Views or opinions expressed herein do not necessarily represent those of the Institute or of its National Member Organizations.

INTERNATIONAL INSTITUTE FOR APPLIED SYSTEMS ANALYSIS
A-2361 Laxenburg, Austria

Preface

The authors use differential equations to describe ecological mechanisms which govern the behavior of the forest ecosystems. The present paper documents, as an example, an ecological model which can be applied to the problem of designing an appropriate environmental monitoring system. The example case also provides a useful link with a class of forest simulation models called "gap models" (Shugart 1984) that simulate the population of trees on a small patch of land (at the scale of a small gap in a closed forest canopy - hence the name "gap model"). In particular, this work considers the case when a simulated gap is sufficiently large. The work can also be used to define the type of periodic behavior expected in the age distribution in a population of trees.

Bo. R. Döös
Leader
Environment Program

PERIODIC BEHAVIOR OF AN AGE-DISTRIBUTED POPULATION OF TREES

M. Ya. Antonovski, M.D. Korzukhin and V.K. Matskiavichus**

In this paper, the age dynamics of a population of trees and a particular case of age dynamics are studied. The method used in the investigation pertains to the formulation of corresponding dynamic models. Following the description of the object and an examination of modeling options, a number of simplified, analytically-studied models are presented, followed by a more realistic, quantitative model of an age-distributed population system with periodic behavior.

1. We are mainly concerned with the Taiga-zone forests. Owing to the perpetual external disturbances of natural succession, the vegetation cover is in a non-stationary state; climax systems are the rare exception (Oliver, 1981). In fact, major taiga disturbances (fires, windfalls, phytofags, climate fluctuations) occur at a frequency that is higher or comparable to the reversed lifespan of trees ($1/10^2$ years). The typical period for fires is 10-30 years in pine stands, 80-100 years in Siberian pine stands, 100-130 years in moist fir stands (Furiaev and Kireev, 1979). The period of droughts that harm Far Eastern fir stands is 40-50 years period of harmful temperature fluctuations in the north of Western Siberia and the Urals is 40-70 years (Komin, 1981). There are more examples. As for the time required for demutational successions to reach their climax, this is comparable to the summarized lifespans of all species which come one after another in a succession, or from 2 to 4 lifespans if there is no species change.

Effects of various type and intensity provide for a virtually infinite number of possible initial situations, which condition subsequent non-disturbed dynamics. Presently, we shall examine an idealized, but probable, instance of single-moment "catastrophes" which entirely obliterate the initial ("maternal") stand, i.e., which provide for zero initial conditions

$$n(t=0, \tau) = 0, \quad (1)$$

where n is the number of trees with age τ , t is time, $t=0$ is the moment of catastrophe. This situation is typical for heavy fires in dark-coniferous taiga, for total phytofag defoliation (after which the trees quickly wither and die or burn-down), for over-mature stands prone to windfalls and, of course, for wholesale cuttings. After $t=0$, we regard outside conditions as stable. Assorted versions of successions with initial conditions (1), as well as their corresponding mechanisms, have been repeatedly described in literature (Buzykin and Khlebopros, 1981; Sedykh, 1979; Smolonogov, 1970, and Oliver, 1981).

Let us examine a single-species system. This approximation is true for situations when one species dominates or when the influence of other species is negligible, even though the species in question is not dominant (for instance, dark conifers with a moderate deciduous fraction).

* Natural Environment and Climate Monitoring Laboratory, GOSKOMGIDROMET, Moscow.

For our purposes, the following properties of the system are relevant. The territory freed by the catastrophe is at first inhabited owing to seed migration or growth of root-based shoots. Let us examine the seed migration from neighboring forest territories, having the intensity of f (seeds per hectare, p.a.) which, for convenience, we shall substitute for a measurable parameter - the number of surviving seeds, i.e., of one-year seedlings

$$\omega = n(t,1) = f \cdot V \quad (2)$$

where f is initial seed migration and V is their survivability.

Evidently, at sufficiently low ω values, the territory is inhabited by a population with monotonous age distribution, $\partial n / \partial \tau < 0$, which attains equilibrium during the lifespan of a single tree, i.e., of one generation. This case is typical for poor habitats or inclement climates (swamplands or forest-tundra subzone). In comparatively richer habitats, the situation is different, provided that ω values are higher: the pioneer species which capture the territory exhaust the environmental resource after a time, causing younger trees of succeeding generations to die in great numbers. We are aware of this situation when younger, shorter trees have their supply of light cut off by taller, older trees. Interception of soil nitrogen is another case (Larher, 1978; *Factors Regulating...*, 1983, and Sprugel, 1976). The result is a "package" of mature trees and a zero-gap in age distribution, which corresponds to junior species (Figure 1a,b), a picture that has been repeatedly described for taiga and deciduous forests (Babintseva, 1970; Falaleev, 1964; Glebov and Kobayakov, 1984; Kazimirov, 1971; Kirsanov, 1976; Krauklis and Bessolitsyna, 1980; Francline and Waring, 1979; Larson and Oliver, 1979; Leak, 1975; Moiseenko, 1971; Oshima et al. 1958; Sabitov, 1977; Semechkin 1970; Stubblefield and Oliver, 1978, and Zubarev, 1965). The time of total suppression of juveniles with the age package varies between 20 (Zubarev, 1965) and 200 (Sabitov, 1977) years. Under milder conditions, suppression is not as strong. It yields a gap with an above-zero number (Day, 1972; *Factors Regulating...*, 1983; Hett and Loucks, 1976, Korzukhin et al., 1988; Karpov, 1983; Moiseenko, 1971; Sedykh, 1979, and Sprugel, 1976) (Figure 1c,d). In both cases, we get the "running wave" (or several waves) along the τ axis. What we are discussing is a non-stationary state resulting from phytocenotic interaction among trees proper, i.e, a situation with unchanging climate and ecological conditions. The waves in age distributions that are generated by, for instance, alterations of the climate (Komin, 1981, and Payette, 1987), are not examined here. (See Katayeva and Korzukhin (1987) for a review on described effects).

Further dynamics may dovetail:

- A. After one or several waves (the largest number known to the authors is 6 - Zybchenko (1982) pine, Kazimirov (1971) *Picea*), the age distribution attains equilibrium.
- B. The systems enters a fluctuating regime, which can be either fully- or quasi-periodic.

Owing to the considerable duration of dynamic development, which entails difficulty of real observation, it is almost impossible to clarify subsequent fate of age distribution measured at a certain moment in time. Natural observations of age distribution for one and the same population appear to be exceptionally rare in natural phytocenosis at different moments in time (the authors are not aware of a single case). A number of works reconstructs age dynamics with observations of different succession phases of populations deployed in comparable habitats (Zubarev, 1965; Kazimirov, 1971; Korzukhin et al., 1988; Semechkin 1970, and Oshima et al. 1958). Obviously, it is more difficult to obtain proof of the existence of a periodic mode than proof of the assumption of a stationary state, as the monotonous nature of the observed $n(t,\tau)$ curve will most likely indicate the

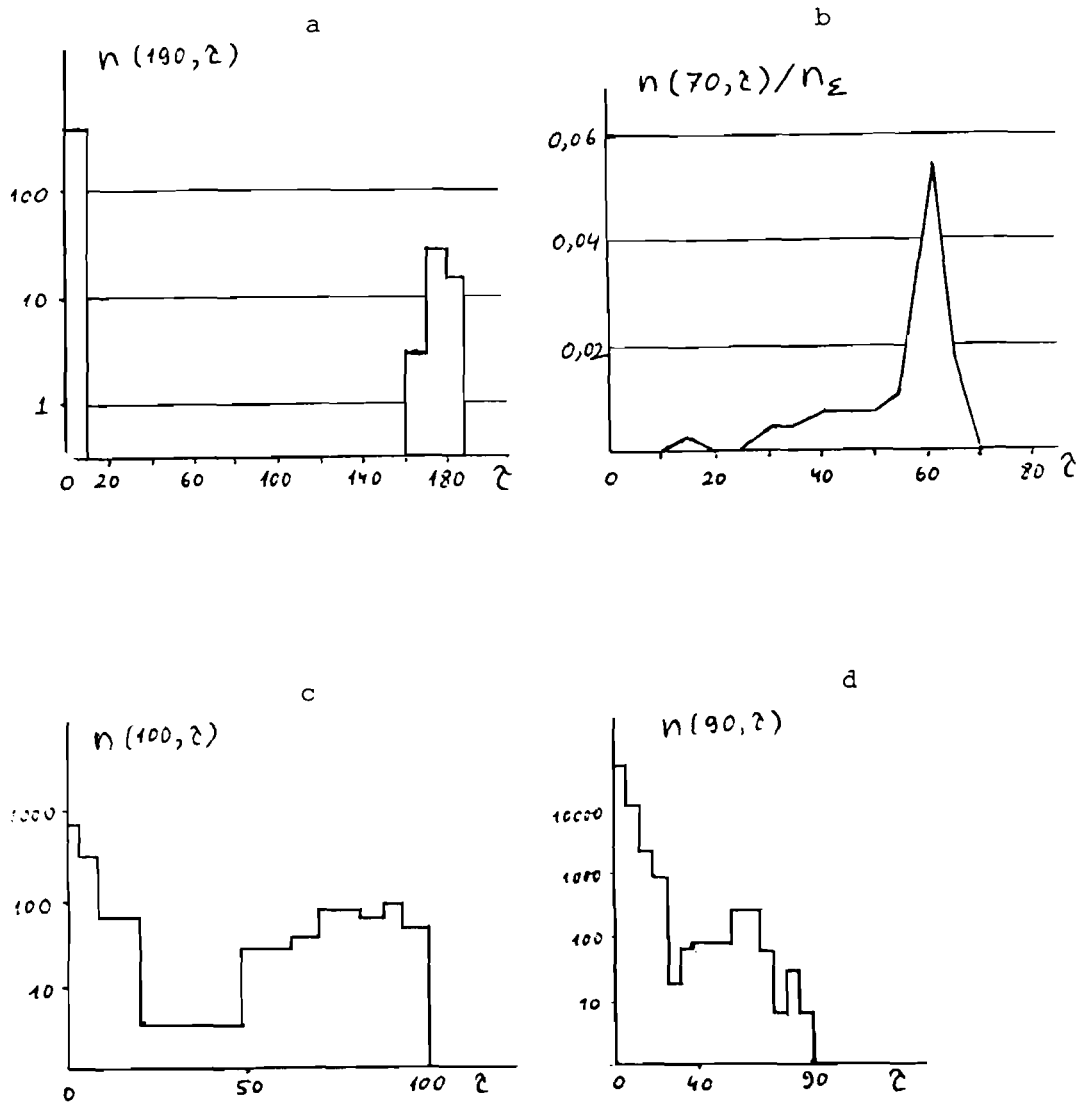

Figure 1: Age waves generated by strong disturbances. Strong suppression of juvenile trees (by canopy):
 a - post-fire succession, Siberian Pine, East Siberia (Semechkin, 1970).
 b - post-cutting succession - summarized for oak, maple, birch, New England (Oliver, 1978). Lighter suppression;
 c - post-fire succession, summarized for *Picea*, *Siberian Pine*, *Abies*, West Siberia (Korzukhin et al., 1988);
 d - Appalachian mixed oak forest (Ross et al., 1982).
 In all cases $n(n, \tau)$ is density of number in the $\Delta\tau = 1$ age interval, n_{Σ} is full number of trees.

onset of equilibrium, whereas a non-monotonous curve (running-wave) can indicate only a transitory process, which only leads to equilibrium.

2. This shows that the conclusions derived in the works cited below on "cyclic reproduction" in forests with a natural genesis are not an established fact but, rather, a reasonable hypothesis.

A terminological clarification should be made at this point. Ecological literature uses the terms *periodic changes*, *cyclic reproduction*, *autogenous cycles*, to describe two types of phenomena:

- A. Mosaic reproduction of forests on the verge of climax in a gap scale (the notion was introduced and used by Watt (1947)). The gap scale is the area of influence of a large single tree. The cycle comprises the occupation of a gap in a canopy left by the fall of a mature tree, competition between the species that take root there, and the die-off and survival of one or two dominant trees at the end of the cycle.
- B. Periodic changes of species accompanied by periodicity in age distributions in territories far exceeding the area of single-tree influence. From the point of view of spatial composition of phytocenosis, these changes are synchronized autogenous cycles in a large number of gaps. This situation is examined below.

The regime of periodic change of species composition or, for one-species systems, of age distributions, is described in the works cited in Table 1.

Table 1: Reported Cases of Forest Oscillations

Type of forest type, species	Region years	Dynamic mechanism	Period,	References
Abies- Deciduous	South of Far East	Prolonged endogenous periodics (PEP)	190-200	Vasiliev and Kolesnikov, 1962
Abies- Picea	Far- East	Prolonged drought- induced periodics	comp. to species lifespan	Kozin, 1982
Siberian- pine deciduous	Far East	PEP	200	Kolesnikov, 1956
Siberian pine	Trans- Urals	PEP	160-200	Kolesnikov and Smolonogov, 1960
Picea	North Urals	Medium- time exo- and endo- genous periodics	50-100	Komin, 1981

Ash	Far East	PEP	280	Korshunov, 1972
Abies-narrow leaved forest	Angara Region	PEP	150	Krauklis and Bessolitsyna, 1980
Picea-Abies	Sikhote Alin	PEP	80-120	Manko, 1967
Siberian pine, dark coniferous broad-leaved	Far East	Prolonged periodics	various depending on site	Moiseenko, 1963
Dark coniferous	Western Sayan	PEP	200	Polikarpov, 1976
Picea-hazel	Smolensk region	Medium-time endogenous periodics	comp. to lifespan of longest-living species	Razumovsky, 1981
Picea-rowan	Moscow region	"	"	
Pine-birch	Moscow region	"	"	
Pine-oak	Crimea	"	"	
Alder	Moscow region	"	"	
Beech	Armenia	"	"	
Picea Ayan	South of Far East	"	"	
Black Abies broad-leaved	Far East, Amur region	PEP	not cited	Rozenberg et al., 1972
and				
Siberian pine broad-leaved		"	"	
and				

Abies- Picea		"	180-200	
Picea- Abies broad- leaved	Near Ural region	PEP	180-200	Smolonogov, 1970
Beech	Crimea	PEP	not cited	Sukachev and Poplavskaya, 1927
Abies	New England, Japan	Medium- time endogenous periodics	60-80	Foster and Reiners, 1983; Moloney, 1986;; Oshima et al., 1958; Reiners and Lang, 1979; Sprugel, 1976
Tsuga	Pennsyl- vania	"	160	Hough and Forbes, 1943
Abies- Tsuga	Great Lakes Region	Prolonged periodics	300	Hett and Loucks, 1976

Following is a brief commentary on Table 1. In accordance with the succession concept proposed by Razumovsky (1981), the reason behind the periodic nature of succession which is observed at times is a deficit of seeds of a species that is to become dominant in the next stage of succession: diasporic climax.

Unfortunately, only several works (Kozin, 1982; Manko, 1967; Moiseenko, 1971; Hett and Loucks, 1976, and Oshima et al. 1958) measured species age distributions. An equally small number of works reported on the area of territory occupied by a single-phase stand - from 0.02 to 1 hectare (Foster and Reiners, 1983; Moloney, 1986, and Oshima et al. 1958).

A separate cycle of works by American and Japanese authors is dedicated to spatial waves in pure dark-coniferous stands (Foster and Reiners, 1983; Moloney, 1986; Oshima et al., 1958; Reiners and Lang, 1979, and Sprugel, 1976). If the system is observed in a single point, it exhibits periodic behavior of age distribution. Spatial waves are generated by synchronization of development phases in spots occupied by approximately even-aged populations owing to strong, uni-directional winds. In the absence of such winds, the territory is occupied by spots with various phases of development (Foster and Reiners, 1983; Moloney, 1986, and Reiners and Lang, 1979).

Judging by the above descriptions, the phytocenotic mechanism of periodicity is, with the exception of Picea-Abies and two-species diasporic subclimaxes, a uni-species one, i.e., based on the properties of a single species or a group of ecologically similar species. The main property responsible for age waves and possible periodicity is the ability of mature individuals within a species to suppress juveniles.

3. Models of periodic age dynamics are few in number. Gimelfarb et al. (1974) contains a general investigation of the linear age-distributed system:

$$n_t + n_\tau = -D(t, \tau)n(t, \tau); \quad n(t, 0) = \int \rho(t, z)n(t, z) dz$$

(where D, ρ are mortality and fertility). The qualitative, three-equation, non-linear model proposed in Korzukhin (1980) describes the suppression of juveniles with mature trees and has a stable limit cycle with a sharp enough mortality dependence on density (see 5 for model development). The model was criticized in Gavrikov (1985) on the basis of an unsubstantiated hypothesis concerning greater competitive power of medium-age groups vs. mature-age groups. The same work made several generalizations of the initial model and concluded that stable oscillations are impossible. A formal description of age-waves is presented in Hett and Loucks (1976), where a sine formula is proposed to approximate empirically observed $n(t, \tau)$ curves.

4. A one-species population system is examined below. The purpose of the model is to prove that when simulation is based on reasonable biological considerations, periodicity may result. There was no parameter fitting for the purpose of adjusting quantitative values to field data, but all parameters that were to be found in reference literature had been taken at values close to those characteristic of conifers. In this way, the digital version of the model described below is a description of the dynamics of a generalized coniferous species, with reasonable individual and population quantitative characteristics. This work expands on the approach used in Korzukhin (1980).

Before passing on to the main part of our work, let us describe two possible mechanisms whereby oscillations appear in an age-distributed population. The first mechanism, which is usually cited by ecologists, pertains to "shock" excitation of oscillations owing to rapid dying-off when the trees reach maximum age. The external factor resulting in the dying-off is drought (Kozin, 1982), strong winds (Moloney, 1986, and Sprugel, 1976) or a phyto- and xylofag attack (Furiaev and Kireev, 1979). In all cases, rooting conditions improve drastically and the previously suppressed young trees start to grow, creating the next age-wave. It is clear that this mechanism can result only in oscillation with the period θ , which equals tree age T . Since the proposed model has no variables descriptive of the dynamics and effects of external factors, the mechanism is recorded via assignment of mortality that starts growing strongly at the age $\tau \simeq T$.

The other mechanism pertains to the appearance of fluctuations in the process of gradual, mature-tree, dying-off. Formally, we may consider lifespan T to be very great, with mortality weakly dependent on age. Evidently, any number of age waves can be generated in the process and $\theta < T$. Below we cite models which make use of both mechanisms.

5. Seeds appear in a territory from two sources: fruit-bearing trees in this territory and the above-described migration from adjacent territories (2), which forms a seed "background". From the point of view of model description, these two sources are totally different: the intensity of the former depends on the state of phytocenosis, while the intensity of the latter does not. As in Korzukhin (1980), let us single out three age classes numbering n_1, n_2 , and n_3 . Let us write the model of age dynamics as follows:

$$\begin{cases} \dot{n}_1 = V(\gamma\sigma)[f + \rho n_3] - n_1 \\ \dot{n}_2 = n_1 - n_2 \\ \dot{n}_3 = n_2 - n_3, \end{cases} \quad (3)$$

where, for simplicity, mortality in class 2 is ignored, the time scale is chosen in such a way that coefficients at linear members are equal unity and both abovementioned sources of seeds are accounted for : ρ is specific fertility in the older class, $V(\gamma\sigma)$ is seed survival depending on the overall leaf area:

$$\sigma = S_1 n_1 + S_2 n_2 + S_3 n_3 \quad (4)$$

where S_i are leaf areas in each class, γ is the efficiency of light absorption on a single transmission through the crown. At $f=0$, the model is somewhat modified Korzukhin (1980). The opposite case is examined below: $\rho = 0$, that is, only the migration of seeds is recognized. Let us consider all interaction to be purely competitive, $dV/d\nu < 0$, $\nu = \gamma\sigma$.

The state of the equilibrium of system (3) $n_1^o = n_2^o = n_3^o = n^o$ loses stability when it is transformed from center to unstable focus on:

$$(3+U_1) (3+2U_1+U_2) < (1+U_1+U_2+U_3) \quad (5)$$

$$U_i = \left| \gamma f S_i \frac{dV}{d\nu} \right| .$$

A centre-type equilibrium point corresponds to equality in (5). Let us cite two concrete cases, accepting $S_1 = 0$ for simplicity.

A. Let $V(\nu) = 1/(1+\gamma\sigma)$, and then equilibrium is found from the equation

$$n^o [1 + \gamma(S_2 + S_3)n^o] = f \quad (6)$$

and is unstable at $n^o > a\sqrt{f}$, where $a = [8/\gamma(S_3 - 2S_2)]^{1/2}$, which with reference to (6) yields $f > a\sqrt{f}[1 + \gamma a\sqrt{f}(S_2 + S_3)]$ and is evidently satisfied at sufficiently large f and $\gamma a^2(S_2 + S_3) < 1$.

B. Let $V(\nu) = \exp(-\gamma\sigma)$. Analogously to the preceding case, it can be found that equilibrium is oscillatory-unstable at

$$f > \frac{8}{\gamma(S_3 - 2S_2)} \exp [8(S_2 + S_3)/(S_3 - 2S_2)] .$$

It is easy to prove that on a weakly-unstable equilibrium, a stable limit cycle appears.

Generalization of system (3) via introduction of class 2 and 3 mortality, $S_1 \neq 0$ and suppression of class 2 with class 3 is, evidently, not sufficient for a qualitative alteration of the results obtained.

6. Now for the dynamic models is discrete time, which have a radical advantage before continuous systems of type (3), since they admit to periodic solutions in explicit form.

6.1. The basic model is, in the simplest form:

$$\begin{cases} n_1(t+1) = V(\sigma_0)f \\ n_2(t+1) = n_1(t) \\ \text{-----} \\ n_T(t+1) = n_{T-1}(t); \\ \sigma_0(t) = S_1 n_1(t) + \dots + S_T n_T(t) \end{cases} \quad (7)$$

Following are solutions of two concrete systems.

6.1.1. Let growth and survivability functions have the form:

$$S_i = a(i-1); \quad (8)$$

$$V(\sigma_0) = \begin{cases} 1, & \sigma_0 < \sigma^* \\ 0, & \sigma_0 \geq \sigma^* \end{cases} \quad (9)$$

$T = 3$ and $n_i(0) = 0$. Then in the plane of parameters (af, σ^*) , three areas can be isolated (Figure 2a).

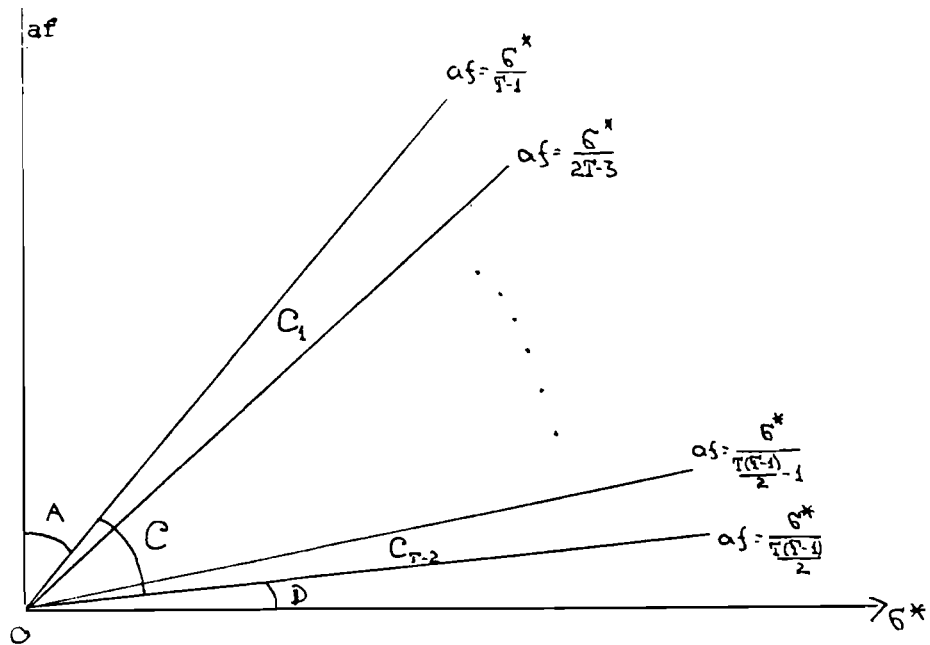

Figure 2a: Behavior of system (7): the parameter plane with main dynamic-behavior types in areas A, C, D.

- A: stable periodic mode with $\theta = 5$ at $af > \sigma^*$ and $\theta = 6$ at $\sigma^*/2 < af < \sigma^*$. The period ends with $n_i(\theta) = 0$.
 C: stable periodic mode with $\theta = 5$, the period ends with $n_1(6) = f$, $n_2(6) = n_3(6) = 0$.
 D: no oscillations, the system attains stable equilibrium $n_i(t) = f$.

6.1.2. Let growth and survivability have the form

$$S = \begin{cases} 0 & i = 1 \\ a = \text{const} & i \geq 2 \end{cases} \quad (10)$$

$$V(\sigma_o) = \begin{cases} 1, & \sigma_o < \sigma^* \\ \beta < 1, & \sigma^* \leq \sigma_i < \sigma^{**} \\ 0 & \sigma^{**} \leq \sigma_o \end{cases} \quad (11)$$

$$a\beta f < \sigma^* < af < \sigma^{**} < (1+\beta)af;$$

then for $T = 4$, the solution with zero initial conditions is as follows:

t	$n_1(t)$	$n_2(t)$	$n_3(t)$	$n_4(t)$
0	0	0	0	0
1	f	0	0	0
2	f	f	0	0
3	βf	f	f	0
4	0	βf	f	f
5	0	0	βf	f
6	0	0	0	βf
7	f	0	0	0

This shows that the system has a stable periodic mode with the period $\theta = 6$.

6.1.3. We studied a system (7) with arbitrary dimensions, growth function (8) and mortality function (9). The overall dynamics is as follows: appearance, passing along the age axis, and disappearance due to transition through age T of age packages (waves) comprising various ages (Figure 2b). As a result, areas with the following types of dynamic behavior are isolated in the parameter plane (Figure 2a):

- A: stable periodic mode with the period $\theta = T + K$, where:

$$K = \left\lceil \frac{\sqrt{8T-7}+1}{2} \right\rceil \geq 2 \quad (12)$$

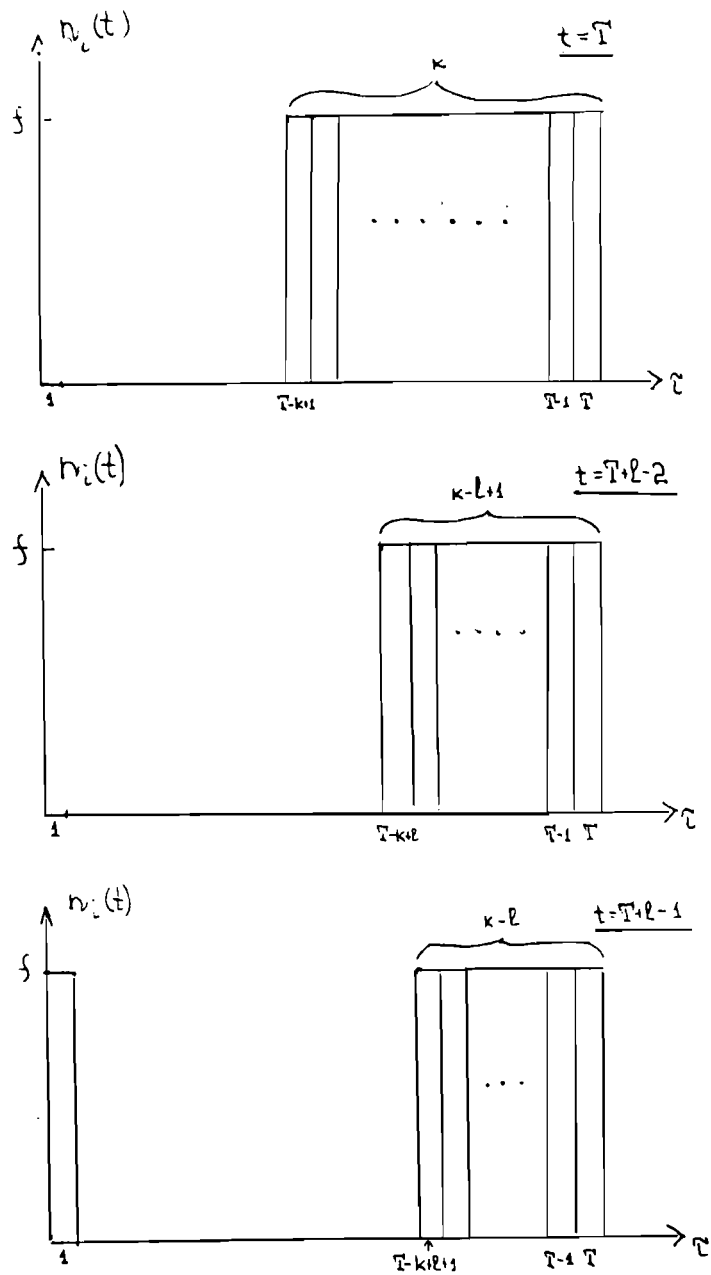

Figure 2b: Passing of age waves with the period $\theta = T + l - 1$ (see text).

([Z] is an integer part of Z). In the corresponding phase of the cycle all ages are reduced to 0, i.e., the solution assumes the form:

$$\begin{aligned} n_i(t) &= (0, \dots, 0) \rightarrow (f, 0, \dots, 0) \rightarrow (f, f, 0, \dots, 0) \dots \\ &\rightarrow (0, \dots, f, f) \rightarrow (0, \dots, 0, f) \rightarrow (0, \dots, 0). \end{aligned}$$

In terms of content, the value of K equals the number of age classes in the resultant package; it is assigned by the condition $\sigma_{k-1} < \sigma^*$, $\sigma_K \geq \sigma^*$, where $\sigma_i = (S_1 + \dots + S_i)f$.

D: no oscillations, the system assumes the state $n_i(t) = (f, \dots, f)$ for $t \geq T$.

C: the area comprises sectors C_1, C_2, \dots, C_{T-2} , assigned by the curves:

$$Z = \frac{\sigma^*}{af} = jT - \frac{j(j+1)}{2}, \quad j=1, \dots, T-1. \quad (13)$$

In each sector there is a stable periodic mode; after the age package disappears, distribution $n_m(t) = f$ for $m < j$ and $n_m(t) = 0$ for $m > j+1$ (j is the sector number) is observed owing to passage through age T (let us consider this moment the end of the cycle).

It can be shown that the period $\theta = T + l = 1$, where

$$2 < l < K + 1 \quad (14)$$

and l and K are introduced below (see also Figure 2b). Let σ^* satisfy the following inequalities:

$$af \sum_{i=1}^{K-1} (i-1) < \sigma^* \leq af \sum_{i=1}^K (i-1); \quad K \leq T.$$

This gives us the maximal value

$$K = \left\lceil \frac{\sqrt{8Z+1}+1}{2} \right\rceil, \quad Z = \frac{\sigma^*}{af};$$

K is the package size at moment $t = K$: $n_1 = \dots = n_K = f$, $n_i = 0$, $i = K + 1, \dots, T$. Since at that moment survivability $V(\sigma_0) = 0$, in the next moment $t = T+1$, a package of K ages appears: $n_1 = 0$, $n_2 = \dots = n_{K+1} = f$, $n_{K+2} = \dots = n_T = 0$. In the moment $t=T$ the package attains age T , after which it grows narrower. $n_1(t)$ will equal 0 until the moment $t = T + l - 2$, when:

$$\sigma_0 = \sum_{i=T-K+l}^T S_i n_i < \sigma^*,$$

which gives us the value of l :

$$l = \left\lceil \frac{\sqrt{(2T-1)^2 - 8Z} + (2K+3-2T)}{2} \right\rceil + 1. \quad (15)$$

In the moment $t = T + l - 1$, the first age class appears (Figure 2b) and by the moment $t = T + K - 1$, the entire preceding package disappears, giving way to the distribution $n_1 = \dots = n_{K-l+1} = f$, $n_{K-l+2} = \dots = 0$, which was observed in the moment $t = K - l + 1$; hence, $\theta = T + K - 1 - (K-l) = T + l - 1$. It is easy to see that l lies within the limits of (14).

It can also be proved (we shall not go into details here) that a new package cannot appear (i.e., became $n_1 = 0$) as long as the remnant of the preceding package exists.

6.2. The closest generalization of the basic model (7) pertains to the introduction of a density-dependent survivability component into each equation describing number dynamics of the cohort:

$$\begin{cases} n_1(t+1) = V(\sigma_0)f, \\ n_2(t+1) = V(\sigma_1)n_1(t) \\ \text{-----} \\ n_t(t+1) = V(\sigma_{T-1}) n_{T-1}(t), \end{cases} \quad (16)$$

where it is accepted that each class is suppressed by older classes of trees (with higher crowns) but not by itself, i.e.,

$$\sigma_i(t) = S_{i+1}n_{i+1}(t) + \dots + S_T n_T(t), \quad i=0,1,\dots,T-1$$

Several particulars were examined for this system.

6.2.1. For the growth function:

$$s_i = \begin{cases} a(i-1), & i < i_0 \\ (i_0-1), & i \geq i_0, \quad i_0=1,2,\dots,T \end{cases} \quad (17)$$

and the survivability function (9), it is possible to isolate areas analogous to those presented in Figure 2a, which means that for every i there is a set:

$$A \quad C_1 \cdots C_j \cdots C_{i_0-2} \quad D,$$

where the boundaries between areas are assigned with curves of the (13) type

$$Z_j = j i_0 - \frac{j(j+1)}{2}, \quad j=1,2,\dots,i_0-1.$$

Dynamic behavior coincides with that of system (7), although the period is constant, equaling $\theta = T+1$.

6.2.2. Let $T = 10$, the growth function be assigned by (10) and survivability $V(\sigma_i)$ have the form (11). Then at $\frac{\sigma^*}{af} = 1$, $\frac{\sigma^{**}}{af} = 1+\beta^7$; the system starts at zero initial conditions and, after 12 steps, enters the cycle with period = 11 (n_i are presented in units f , zero values are unmarked):

t	$n_1(t)$	$n_2(t)$	$n_3(t)$	$n_4(t)$	$n_5(t)$	$n_6(t)$	$n_7(t)$	$n_8(t)$	$n_9(t)$	$n_{10}(t)$
12	1	β								
13	1	1	β							
14			1	β						
15				1	β					
16					1	β				
17						1	β			
18							1	β		
19								1	β	
20									1	β
21										1
22	β									
23	1	β								

6.2.3. We studied the general case of system (16) with an arbitrary T , a step function of $V(\sigma_i)$ - (9), and growth function (8). As for system (7), the following was proved.

- A: The period of fluctuation is constant and equal $\theta = T+1$. At each moment in time, no more than one package (wave) can exist on the age axis.
- B: As in system (7), the plane of (af, σ^*) parameters is crossed with straight lines (13) and divided into areas with identical types of dynamic behavior. Besides the constant nature of the period, this behavior also differs, in that suppression by older ages at a certain moment in time can cause the death of more than one age class.

6.3. The following generalization of the basic model involves the introduction of the density-independent mortality component:

$$\begin{cases} n_1(t+1) = W_0 V(\sigma_0) f, \\ n_2(t+1) = W_1 V(\sigma_1) n_1(t) \\ \text{-----} \\ n_T(t+1) = W_{T-1} V(\sigma_{T-1}) n_{T-1}(t). \end{cases} \quad (18)$$

Let us examine only the constant function W :

$$w_i = e^{-\lambda}, \quad i=0,1,\dots,T-1. \quad (19)$$

From the numerous possible assessment of system behavior, let us cite three.

6.3.1. Let T be finite, survivability specified by formula (9), and the growth trend such as to conform to $\nu_i > \nu_{i+1}$, where $\nu_i = S_i n_i$. Let us first point out that for a stable equilibrium it is necessary and sufficient that $\sigma_0^{stab} < \sigma^*$ or

$$\sigma_0^{stab} = \sum_{i=1}^T \nu_i = \sum_{i=1}^T S_i f e^{-\lambda i} < \sigma^* \quad (20)$$

For oscillations or any unstable behavior of any type to be observed, it is necessary and sufficient for σ_0^{stab} to be greater or equal to σ^* . Let us consider the condition of stability is weakly violated, i.e., $\sigma^* = \sigma_i^{stab} - \epsilon$, where ϵ makes $\nu_T < \epsilon < \nu_{T-1}$. Consequently, it is easy to see that the system (18) exhibits fluctuations with the period $\theta = T$, and single-age gaps between packages.

6.3.2. The case of $T = \infty$ with survivability functions (9), (19) and linear growth. Let us consider age to be continuous for simplicity, i.e., $S(\tau) = a\tau$. For stability of age distribution it is necessary and sufficient

$$\sigma_0^{stab} = \int_0^{\infty} S(\tau)n(\tau)d\tau = af \int_0^{\infty} \tau e^{-\lambda\tau} d\tau = \frac{af}{\lambda^2} < \sigma^* .$$

Let us mark

$$\mu_i = \int_{i-1}^i \mu(\tau) d\tau$$

and choose

$$\epsilon \leq \mu_1 = \mu_1(af, \lambda), \sigma^* = \sigma_0^{stab} - \epsilon \quad (21)$$

Then, let us introduce minimal age q and maximal age p , both of which could provide for (Figure 3):

$$\sigma_q = \int_q^{\infty} \mu(\tau) d\tau \leq \epsilon, \mu_p = \int_{p-1}^p \mu(\tau) d\tau \geq \epsilon . \quad (22)$$

At zero initial conditions, the first gap appears at $t=q+1$; q is the size of the first package; gap size equals one year. From the conditions of (22), it is apparent that the second gap must appear not earlier than the first reaches age p and not later than it reaches age q (Figure 3). The same is true for subsequent gaps. Hence, the system exhibits fluctuations with the period

$$p \leq \theta \leq q$$

in the form of waves divided by single gaps.

6.3.3. Let us conclude our analysis with a somewhat exotic instance of two-period oscillations. Assigning growth and survivability as in the preceding example, T as finite and even, the stability condition as weakly violated and ϵ is equal or greater than $\mu_{T-1} + \mu_T = S_{T-1}fe^{-\lambda(T-1)} + S_Tfe^{-\lambda T}$; let us choose a λ to provide, at $K = T/2 - 1$, for $\mu_K = S_K n_K = \mu_{T-1} + \mu_T$. Then the system can be shown to have oscillations in the form of two juxtaposed waves with dimensions of $\theta_1 = K - 1$, $\theta_2 = K+2$, and with a single gap between. The picture repeats itself after $\theta = \theta_1 + \theta_2 + 2 = T+1$.

7. Now let us examine the far more realistic age-distributed demographic model based on our previous studies (Antonovsky and Korzukhin, 1986, 1988; Korzukhin, 1986; Korzukhin and Ter-Mikaelyan, 1982; Korzukhin et al., 1987, 1988). The model covers growth, reproduction and mortality; the central process ensuring interaction is competition which leads to considerable non-linearity of equations that are open only to numerical investigation.

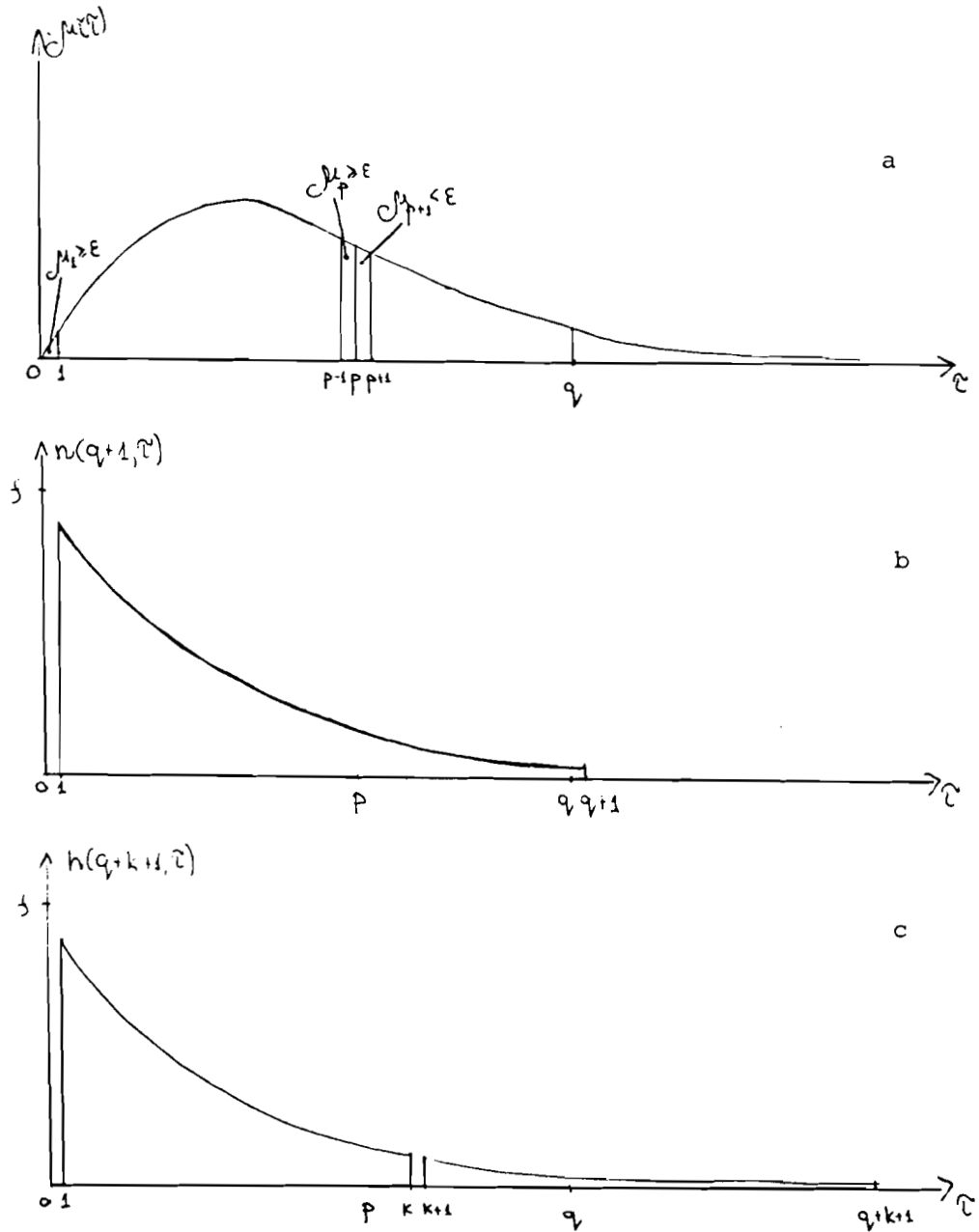

Figure 3: Appearance of instability in system (18).
 $a - \mu(\tau) = S(\tau)n(\tau)$ dependence;
 b, c - scheme of waves passing with the period $p \leq \theta \leq q$. See text.

For each cohort of age τ , two variables are introduced: individual biomass $m(t, \tau)$ (mass units are best chosen depending on concrete data - [kg] CO₂, CH₂O or raw mass). The second is the number of trees to a cohort - $n(t, \tau)$ (trees per hectare). Below, the age and time unit is one year.

We make use of the simplest growth equation which has one m variable and is based on the generally accepted principle of carbon balance

$$\begin{aligned} m(t+1, \tau+1) &= m(t, \tau) + S(m)A(R) - rm(t, \tau); \\ \tau &= 1, \dots, T-1. \end{aligned} \quad (23)$$

The equation is applied to all of the trees in a cohort. $S(m)$ is leaf area [sq.m] which is further described by the power function

$$S(t, \tau) = am^\alpha(t, \tau). \quad (24)$$

According to numerous morphological data (Molchanov, 1971; Smirnov, 1971, and *Structure and Productivity*, 1973), this ratio confirms best to moderate-zone tree species. A is the specific rate of net assimilation in the same mass units as m , $[A] = [\text{kg p.a. per sq.m}]$. r is the summarized dying-off coefficient and respiratory expenses, [kg p.a.]. $R = R(t, \tau)$ is the population-averaged amount of light falling on a sq.m of leaf area of a species with the age of τ . This function is central for the model; it depends on population density, type of spatial deployment, morphology and tree height. For our goals, the elementary model of a single-layered horizontal crown is adequate. For a population of trees with such crowns,

$$R(t, \tau) = I_0 \sin \Psi \exp[-1/2 \gamma S(t, \tau) n(t, \tau) - \gamma \sum_{\mu=\tau+1}^T S(t, \mu) n(t, \mu)] \quad (25)$$

where I_0 is the initial light flow (in any units), Ψ is average sun angle, γ is the light-absorption coefficient for a single transmission through the crown. The adopted crown morphology means that a tree of age τ is overshadowed by all higher-standing trees and only by them (similar to the technique adopted in Botkin et al. (1972), and Shugart (1984)), as well as half of that tree's cohort, with reference to weak blurring along the height coordinate - hence the member with 1/2.

The form of function $A(R)$ is chosen depending on the task; here it is sufficient to take:

$$A(t, \tau) = bR(t, \tau). \quad (26)$$

Formulas of cohort number dynamics coincide with those used above and in (Antonovsky and Korzukhin, 1988, and Korzukhin et al., 1987, 1988):

$$\begin{cases} n(t+1, 1) = U[f + \sum_{\tau} \rho(R, \tau) n(t, \tau)], \\ n(t+1, \tau+1) = W(\tau) V(R) n(t, \tau) \end{cases} \quad (27)$$

$$\tau = 1, \dots, T-1.$$

Here, ρ is fertility depending on age and available resource, U is survivability of seeds, $W(\tau)$ is the density-independent survivability component.

7.1. The $V(R)$ function - the density-dependent survivability component - deserves special discussion. We are aware of over 20 works which link survivability to various factors or variables of the individual; the main are size, growth rate, one or another competitive-pressure characteristic, and species. As a general rule, survivability grows on rising growth rate, weakening competitive pressure, and the concave form of function V , on which there is a sharp dependence of the type shown in Figure 4 (Buchman et al., 1983).

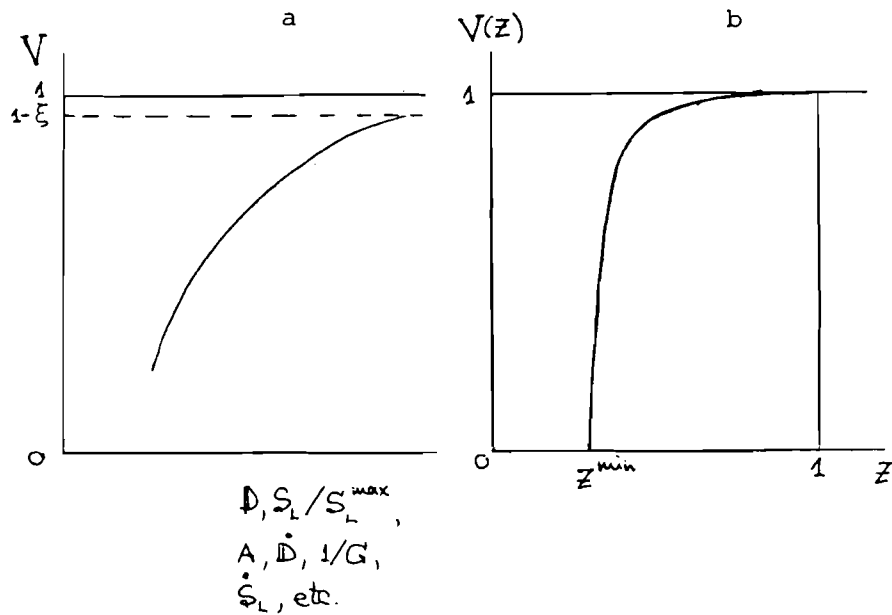

Figure 4: Qualitative dependence of survivability V on a number of arguments:
 a: in accordance with empirical dependences and models (Blagovidov, 1984; Buchman et al., 1983; Glover and Hool, 1979; Hamilton, 1974; Mitchell, 1975, and Monserud, 1976). The X axis has arguments introduced in the text; ξ is mortality of mature free-growing tree;
 b: density-dependent survivability component (29) used in quantitative model (23)-(27);
 $z^{\min} = A^{\min}/A^{\max}, A^{\min}$ is intensity of support respiration.

An analogous dependence on the amount of needles (actually, on net tree photosynthesis) was established for pine (Blagovidov, 1984). Several works proved that empirical data harmonize with a function $V = 1 + e^{-\varphi}$, where $\varphi = \varphi(D)$ (Hamilton, 1974; $\varphi = \varphi(D, \dot{D}$, competition index) - linear function (Monserud, 1976); here, D is diameter. For several species, Buchman et al. (1983) discovered non-monotonous behavior of $V(D)$: survivability may attain a maximum in intermediate sizes: in other cases V is weakly dependent on D . The dependence $V(G)$ of the type presented in Figure 4 was discovered in Glover and Hool (1979). Mitchell (1969) made use of survivability having the form $V = V(S_L/S_L^{\max})$, where S_L, S_L^{\max} are real and maximal (at this age) crown area. Newnham and Smith (1964) used

$$V(\dot{D}) = \begin{cases} 1 & \text{at } \dot{D} > \text{const.} \\ 0 & \text{at } \dot{D} < \text{const.} \end{cases}$$

An analogous dependence was used in Aikman and Watkinson (1980), where \dot{D} was substituted with \dot{S} , and in Mäkelä (1986):

$$V(\dot{m}, \dot{m}_L) = \begin{cases} 1 & \text{at } \dot{m}_L > 0 \\ 1 - |\dot{m}_L/\dot{m} \cdot \text{const}| & \text{at } \dot{m}_L \leq 0 \end{cases}$$

where m_L is needle mass. Yet another threshold dependence was used in Mitchell (1975) where, for each tree,

$$V(G) = \begin{cases} 1 & \text{at } G = nD^2 < \text{const} \\ \text{value preserving } G = \text{const}, & \end{cases}$$

i.e., the 3.2 law was in fact applied. According to the gap-modeling technique (Botkin et al. (1972) and Shugart (1984)) for each tree

$$V(\dot{D}) = \begin{cases} 10^{-2/T} & \text{at } \dot{D} > 1 \text{ mm p.a.} \\ 10^{-0.2} & \text{at } \dot{D} < 1 \text{ mm p.a.} \end{cases}$$

(in the former case, 1% survives until age T , in the latter - until the age of 10).

The above review indicates that even on constant environmental pressure, survivability is a complex characteristic depending on variables of state (D, S) and their dynamics (\dot{D}, A); in population-level models, it also depends on G or equivalent parameters. Also possible is the dependence on arguments of the S_L/S_L^{max} type, which means that the tree "remembers" the size it could have had, had it grown freely. It is also apparent that the theory of survivability is not developed to a degree that would allow for its constructive application with an accuracy yielded, for example, by the growth equation (23). In this situation, it is only natural to select a semi-empirical model which admits to a reasonable biological substantiation. The widest-spread dependences which connect V with absolute increment are uncomfortable, since they blow up the mortality values of young and old trees as compared to average-aged trees. Proceeding from the original version of the survivability model (Korzukhin, 1986), we rejected the "memory"-related arguments and used an argument equal to the relative assimilation rate:

$$V = V[A(R)/A^{\text{max}}] \quad (28)$$

where $A^{\text{max}} = A(R^{\text{max}}) = A(I_0 \sin \Psi)$. Further on, we make use of the following form of function (28) (Figure 4):

$$V(t, \tau) = 1 - p \left(\frac{1-z}{1-u} \right)^\beta; \quad z = A[R(t, \tau)]/A^{\text{max}} \quad (29)$$

$p < 1$, $u < 1$, β are parameters.

7.2. We attempted a search for periodic solutions and studied accompanying effects in system (23) - (27) with the survivability function (29). Following is a brief description of relevant parameters. Species lifespan $T = 200$. The usually encountered value of α in allometric dependences (24) is $0.5 < \alpha < 0.9$; for calculations, it was considered $\alpha = 0.7$.

The value of a was based on that by the end of a lifespan, $a_1 = m_L / m_{\max} = 0.05$ (Larher, 1978). It was accepted $m_{\max} = 1000\text{kg}$ (raw height). The coefficient of transition from needle mass to its surface $a_2 = m_L / S_L = 0.15$ (kg of raw needles/sq.m) - (Molchanov, 1971; Smirnov, 1971, and *Structure and Productivity...*, 1973). From these ratios $a = a_1 m_{\max}^{1-\alpha} / a_2 = 2.65$. The maximal leaf area of a freely-grown tree $S^{\max} = S(m_{\max}) = 334$ sq.m and maximal foliage biomass $m_L^{\max} = 50$ kg of raw weight.

In the equation for R (25), I_0 can be adopted as 1; Ψ equaled 0.76 [rad.].

Then the b coefficient on (26) will equal maximal photosynthesis, whose typical value is of the 10^{-1} order (kg of raw weight of wood per sq.m of foliage p.a.) - (Larher, 1978); b was taken at 0.15. The r parameter in (23) can be found from the condition of free individual growth $m \rightarrow m_{\max}$, i.e., $am_{\max}^{\alpha} b \sin \Psi - r m_{\max} = 0$, which yields $r = 0.034$ [l/kg p.a.]. We examined only seed background, i.e., accepted in (27) that $\rho(\tau) = 0$ (earlier, we attempted to compare the intensities of two seed sources with a quantitative succession model (Korzukhin et al., 1988); the result says that $\Sigma \rho n / f \simeq 0.2$). f was interpreted as the number of surviving seeds, i.e., $U = 1$. Density-independent survivability $W(\tau)$ in (27) was equal to $const < 1$, so that in the absence of competition, the size of each cohort registered an exponent fall. We used $w(\tau) = 0.98053$ (by the age $\tau = 200$, 0.02 trees are left). The empirical value of the absorption coefficient, γ has the order of several decimals. The values of γ , f , β and u were varied in the search for the oscillations. p equaled 1/2. In this way, we experimented with a generalized tree species having plausible parameter values from among those given to measurement and a number of free parameters that either resisted measurement or changed in certain reasonable limits for the search of oscillations or investigation of system behavior.

The system was calculated up to $t^{\max} = 2000$; the time of calculation on a EC1060 computer was roughly 8 minutes.

8. The results are in Figures 5-8 and in text.

8.1. Figure 5 shows the behavior of a number of characteristics of the system for $f = 1000$, $\beta = 60$, $u = 0.15$, as well as for the change of γ from 0 to 1 (the latter corresponds to the impermeable crown). Until $\gamma \simeq 0.2$, the system attains stable equilibrium. Near $\gamma = 0.22$, the equilibrium becomes unstable, and a stable periodic mode (Figure 6) with the period $\theta = 88$, sets in. For convenience of comparison of $n(t, \tau)$ curves, they were phase-shifted at various γ with connection of one maximum to $\tau = 100$ (Figure 6). Figure 5 shows the behavior of $n^{\max}(t, 100)$ and $n^{\min}(t, \tau^{\min})$, where τ^{\min} is the closest age of the minimal density before $\tau = 100$. It is apparent that the value of n^{\max} undergoes little change, whereas n^{\min} is greatly reduced. High stability is observed for the period, $80 < \theta < 88$ period.

Let us point out the behavior of a key population characteristic - the leaf index $\sigma = 10^{-4} \Sigma S(t, \tau) n(t, \tau)$ (the multiplier was introduced for the transfer to the numbers per one sq.m; σ equals the number of foliage layers in the stand). Beyond $t \simeq 100$, the system quickly assumes a relatively constant value of σ (on oscillation, the relative variation of $\Delta\sigma / \sigma^{\text{med}} \simeq 0.15$). This behavior is harmonious with the picture observed in real even- and multi-aged stands, which characteristically use the maximum of environmental resources (in this case, light), which corresponds to the maximal foliage index value.

At $\gamma = 0$ (Figure 5), σ is very large and equals 215, a totally unreal value for natural phytocenosis. Then $\sigma(\gamma)$ falls quickly, attaining reasonable values already at $\gamma = 0.1$ (Larher, 1978; *Structure and Productivity...* 1973, and *Factors Regulating...*, 1983).

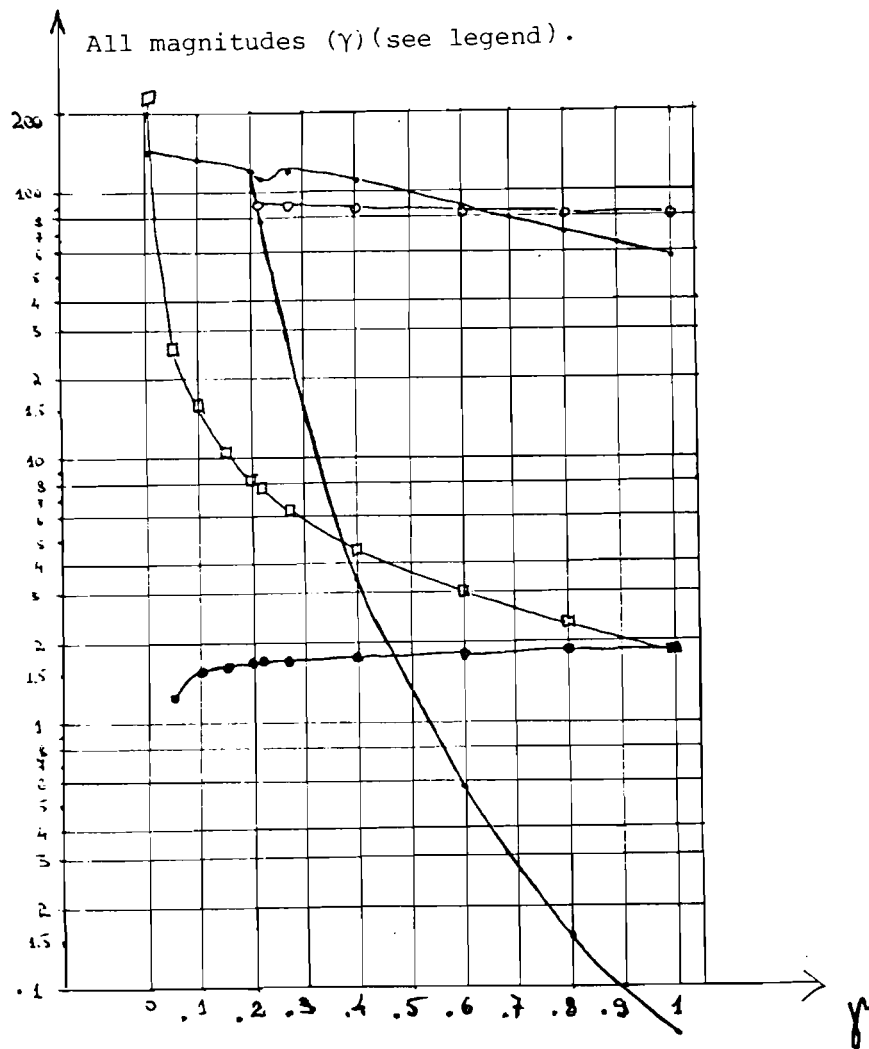

Figure 5: Behavior of several characteristics in (23)-(27) on changing γ . The two curves (·) resulting after $\gamma = 0.2$ - amplitude of the first wave from Figure 6, i.e., $n^{\max} = n(t, 100)$ and $n^{\min} = n(t, \tau^{\min})$. (○) is the oscillation period θ . (□) is value of leaf area index σ at the moment $t = 2000$. (●) is $J = \gamma\sigma$ value.

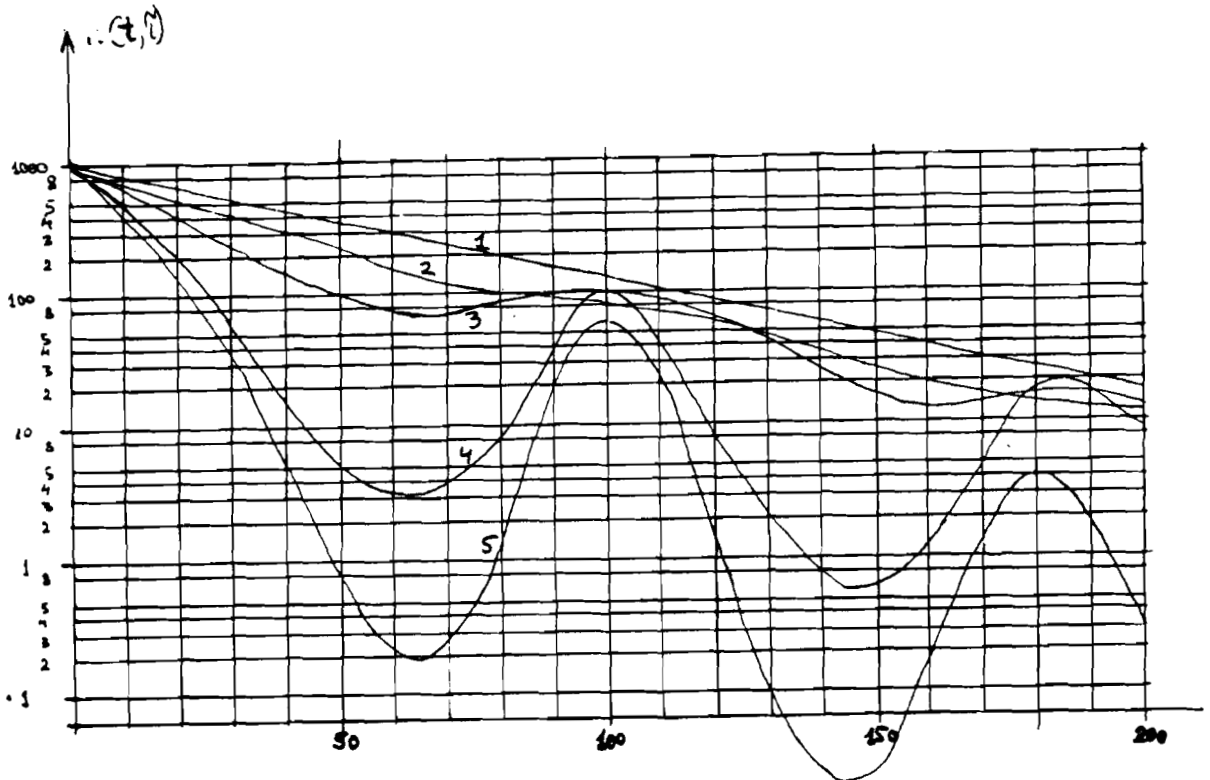

Figure 6: Behavior of the (23-27) system at gamma values taken from Figure 5: 1,2 are stable distributions of $n(t, \tau)$ at $\gamma = 0, 0.2$; 3,4,5 represent the stabilized periodic regime at $\gamma = 0.226, 0.4, 0.8$, respectively.

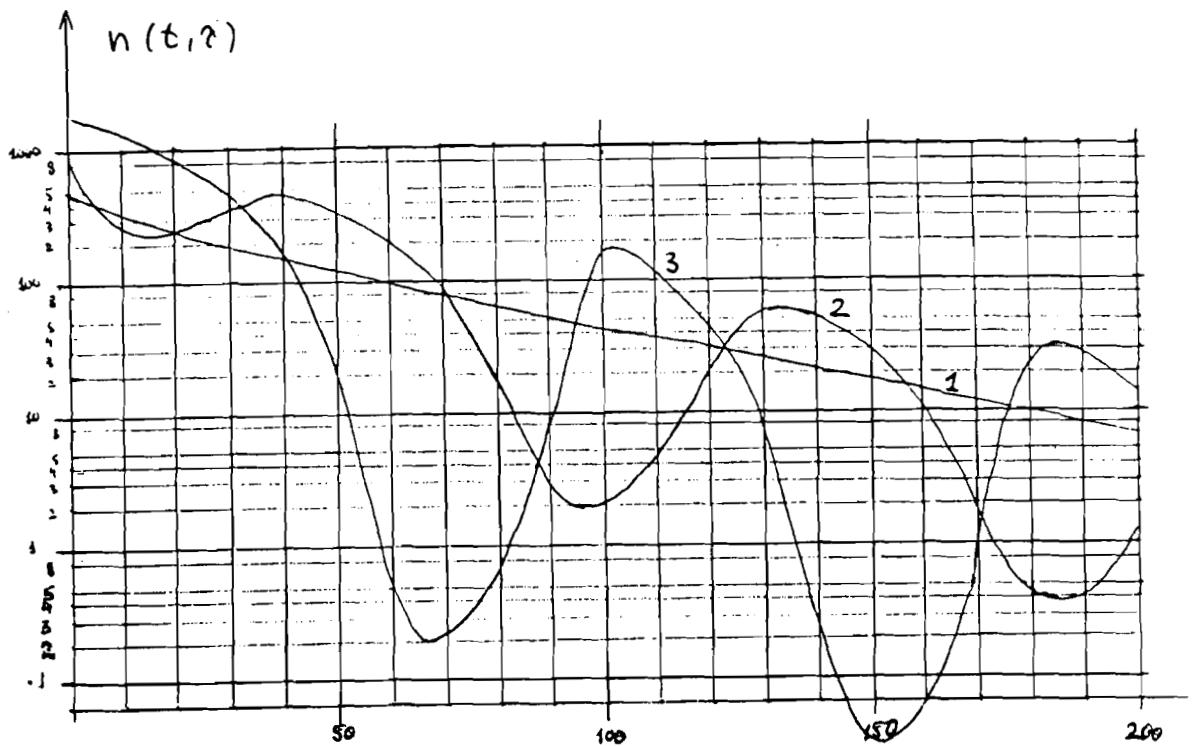

Figure 7: Behavior of the (23)-(27) at various seed migration intensities. 1 is stable distribution at $f = 500$; 2,3 - stable oscillations at $f = 1000, 2000$.

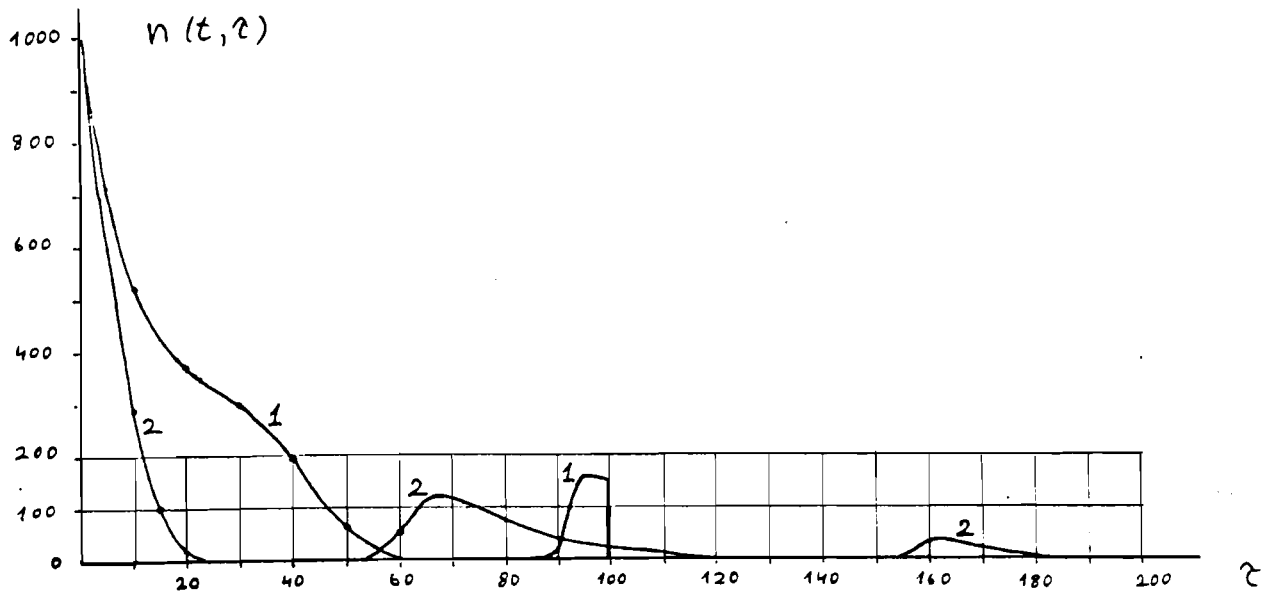

Figure 8: First age wave (1) and stable oscillations (2) in the (23)-(27) at $\gamma = 0.4, u = 0.2$.

8.2. From the discovered effects, the greatest interest is aroused by the appearance of an invariant in the system (Figure 5):

$$J = \gamma\sigma(\gamma, f, u) \simeq const \quad (30)$$

whose value weakly depends on changing γ and other parameters. Note that the magnitude $\gamma\sigma$ is the argument of the function $R_{\min} = I_0 \sin \Psi \exp(-\gamma\sigma)$ (see (25)), the average amount of light reaching the ground level. Table 2 presents the values of $\sigma, J(\gamma, f, u)$ on calculation for parameters γ, f, u . Values of σJ are taken for $t = 2000$.

Table 2: Dependence of leaf area index σ (first number) and invariant J (second number) upon system parameters.

		u = 0.1			u = 0.2		
		0.2	0.4	0.6	0.2	0.4	0.6
$f \backslash \gamma$							
500		7.6 1.52	4.4 1.76	3.1 1.86	7.0 1.40	3.2 1.28	2.4 1.44
1000		8.9 1.78	4.8 1.92	3.4 2.04	6.3 1.26	3.4 1.36	2.6 1.56
2000		9.5 1.90	4.9 1.96	3.6 2.16	6.9 1.38	3.9 1.56	2.5 1.50

The appearance of invariant (30) is qualitatively comprehensible: $J = \gamma\sigma$ equals the amount of light absorbed by a unit of phytocenotic surface. The constancy of J obtained in the model is a strong testimony of its correctness.

Also of interest is the appearance of another invariant - of the oscillation period $\theta(\gamma, f, u)$, which, however, does not provide for a simple interpretation. Figure 4 shows the dependence $\theta(\gamma, 1000, 0.15)$ and Table 3 - $\theta(\gamma, f, u)$, for parameter values from Table 2, along with other characteristics of system behavior. It is evident that the system grows unstable on increasing γ, f, u . Also observed is a mode of quasiregular oscillation, at least within the limits of calculated time. Their main physiognomic trait is the transition from two age peaks (Figure 6) to three (Table 3 contains the θ range).

Table 3: Dependence of $\theta(\gamma, f, u)$, oscillation period, and other characteristics of system behavior.

		u = 0.1			u = 0.2		
γ	f	0.2	0.4	0.6	0.2	0.4	0.6
500		stable equilibrium		SE	SE	86	86
		SE					
1000		SE	SE	85	86	82	43-71
2000		SE	82	82	83	52-68	49-66

8.3. We studied the ecologically important behavior of the system at various intensities of seed migration, f . At $u = 0.1$ (Table 2), the value of σ grows slowly with growing f , and at $u = 0.2$ is virtually stable. Here we are witnessing a "habitat saturation" effect which is observed in real phytocenoses and explained, as above, by maximal utilization of environmental resources. The overall quantity of foliage cannot exceed a certain limit specified by crown morphology and physiological parameters. This effect has been studied earlier (Antonovsky et al. 1985, Korzukhin et al. 1988) on a model of succession in which the dynamics of individual growth did not depend on number dynamics.

For $\gamma = u = 0.2$, the loss of equilibrium stability occurs at $500 < f < 1000$; stabilized oscillations for $f = 1000, 2000$, are shown in Figure 7.

8.4. As shown by calculation experiments, a sufficient curvature of $V(Z)$ function (see (29) and Figure 4) is necessary for the appearance of oscillations. The influence of parameters p, β, u , is seen from the form of the derivative at the $Z=u$ point: $dV/dZ = -p\beta/(1-u)$. It is worth mentioning that the used value of $\beta = 60$ yields a "near-step" function $V(Z)$ which is close to pure-step survivability functions, which are used in several models (Botkin et al., 1972; Mäkelä, 1986; Newnham and Smith, 1964, and Shugart, 1984).

8.5. We studied the dynamics of formation and passing of the first age wave, which is of interest for forest ecology regardless of the possibility of stable oscillations. We plan to present a detailed assessment of results later. Here we wish to point out that the first age wave is much higher and narrower than the succeeding ones (Figure 8). One can see that $t=100$, the system is on the verge of generating a new wave.

9. According to the methodological result of our work, the "classical" ecological-modeling technique continues to provide new possibilities in the understanding of population dynamics. These possibilities are evidently under-estimated by supporters of the "new individually-based" modeling approach (Huston et al., 1988) which discusses, in our terms, the conditions of emerging the age-waves and states that "these different patterns cannot easily be distinguished using state-variable population models." This, however, has been done above. We believe that the general rule is that there are no "best" models proper, their convenience is a question of aim and cost; the modern passion for computer-oriented imitational models can lead to a temptation to lower the efforts in understanding the object.

The specifics of distributed systems studied in this work pertain to the strictly indirect character of interaction: taller trees suppress shorter ones, and not vice versa. The next step is the examination of a more realistic situation of vertically distributed crowns, which make shorter trees influence taller ones, i.e., of connections of tree groups within certain ranges of height and age. The property of periodicity of age dynamics should remain in this case, as well; it appears that the invariant (30) will also remain. However, the appearance of new phytocenotic effects is possible. We plan to study these effects in the future.

REFERENCES

- Aikman, B.P., and A.R. Watkinson. 1980. A model for growth and self-thinning in even-aged monocultures of plants. Moscow: Annals of Botany. v.45, n.4, p.419-427.
- Antonovsky, M.Ya., and M.D. Korzukhin. 1986. Predictive forest ecosystem models and implications for integrated monitoring. Working Paper WP-86-36. Austria: International Institute for Applied Systems Analysis, Laxenburg.
- Antonovsky, M.Ya., M.D. Korzukhin. 1988. Forecast models of the dynamics of forest phytocenosis in background monitoring. In: Problems of Ecologically-Stable Development of the Biosphere. Materials of Int. Symp. Leningrad/Moscow: Gidrometeoizdat Publ., p.49-67 (in Russian).
- Antonovsky, M.Ya, M.D. Korzukhin, and M.T. Ter-Mikaelyan. 1985. Mathematical Modeling of Anthropogenic Changes of Forest Ecosystems. In: Scientific Substantiation of an Environmental-Monitoring System. Materials of 1st Soviet-French Symposium. Leningrad: Gidrometeoizdat Publ. p.86-96 (in Russian).
- Babintseva, R.M. 1970. Age structure of dark-conifer stands in Tomsk Oblast. In: Forest Studies in Siberia. Krasnoyarsk: Forest Inst. Acad. Sci. v.2, p.59-72 (in Russian)
- Botkin D.B., J.F. Janek, and J.R. Wallis. 1972. Some ecological consequences of a computer model of forest growth. J. Ecol. v.60, p.849-872.
- Buchman, R.G., S.P. Pederson, and N.R. Walters. 1983. A tree survival model with application to species of the Great Lakes Region. Canadian Jnl. Forest Reserve. v.13, p.601-608.
- Day, J.R. 1972. Stand structure, succession, and use of Southern Alberta's Rocky Mountain Forest. Ecology. v.53, no.3, p.472-478.

- Blagovidov, A.K. 1984. Structural changes in young pure pine stands due to pest defoliation. In: Problems of Forest Protection. Moscow: Forest-technol. Inst. v.156, p.45-50 (in Russian).
- Buzykin, A.I., and R.G. Khlebopros. 1981. Formation and change of conifer generations. In: Time-Spatial Structure of Forest Biogeocenoses. Novosibirsk Publ. p.3-13 (in Russian).
- Factors Regulating Spruce Stand Ecosystems. Karpov V.G. (ed.). Leningrad: Science Publ. (in Russian).
- Falaleev, E.N. 1964. Abies stands in Siberia and their comprehensive utilization. Moscow: Forest Industry Publ. (in Russian).
- Foster, J.R., and W.A. Reiners. 1983. Vegetation patterns in a virgin subalpine forest at Crawford Notch, White Mountains, New Hampshire. Bull. Torrey Bot. Club. v.110, p.141-153.
- Francline, J.F., and R.M. Waring. 1979. Distinctive features of the north-western coniferous forest: development, structure and function. In: (Ed.) R.M. Waring. Forests: Fresh Perspectives from Ecosystem Analysis. Proc. of the 40th Annual Biology Coll., Oregon: Oregon State Univ. Press, Corvallis. p.59-85.
- Furiaev, V.V. and Kireev, D.M. 1979. Study of post-fire dynamics on landscape basis. Novosibirsk Science Publ. (in Russian).
- Gavrikov, V.L. 1985. Age dynamics of tree populations. In: Analysis of Tree Cenosis Structure. Novosibirsk: Science Publ. p.50-70.
- Gimelfarb, A.A., L.R. Ginzburg, and R.A. Poluektov. (1974). Dynamic theory of biological populations. Moscow: Science Publ. (in Russian)
- Glebov F.Z. and M.V. Kobayakov. 1984. Influence of swamping and fires on growth and productivity of stands. In: Productivity of Forest Phytocenoses. Krasnoyarsk: Siberian Branch Acad. Sci. Publ. (in Russian).
- Glover, G.R. and J.N. Hool. 1979. A basal area ratio predictor of Loblolly Pine Plantation mortality. Forest Science. v.25, no.2, p.275-282.
- Hamilton, D.A.G. 1974. Event probabilities estimated by regression. US Forest Service Research Paper INT.
- Hett J.M. and O.L. Loucks. 1976. Age structure models of Balsam Fir and Eastern Hemlock. J. Ecol. v.64, p.1029-1044.
- Hough, A.F. and R.D. Forbes. 1943. The ecology and silvics of forests in the high plateaus of Pennsylvania. Ecol. Monogr. v.13, p.299-320.
- Huston, M., D. DeAngelis, and W. Post. 1988. New computer models unifying ecological theory. BioScience, v.38, p.682-691.
- Karpov, V.G. 1983. Synecological analysis of the struggle for life in spruce forests. In: Questions of Forest Genetics and Phytocenology. Moscow: Science Publishers. p.32-73 (in Russian).
- Katayeva K.V. and M.D. Korzukhin. (1987). Dynamics of Dark-Conifer Siberian-Pine Forests. Moscow: Lab. of Envir. Monitoring Publ. (in Russian).
- Kazimirov, N.I. 1971. Karelian Fir Stands. Leningrad Sci. Publ. (in Russian).
- Kirsanov, V.A. 1976. Formation and Development of Green-Moss-Berry Siberian-Pine Stands in the North Urals. Sverdlovsk: Proc. Animal and Plant Ecology Inst. Acad. Sci. v. 101, p.104-113 (in Russian).
- Kolesnikov, B.P. 1956. Siberian-Pine Forests in the Far East. Vladivostok: Proc. Far East Branch Acad. Sci., Ser. botan, v.2(4) (in Russian).

- Kolesnikov, B.P. and Y.P. Smolonogov. 1960. Relevant Trends of Age and Reproduction Dynamics of Siberian Pine Stands in Trans-Ural Ob Regions. Novosibirsk: Proc. Forest Econ. of Siberia. v.6, p.21-33 (in Russian).
- Komin, Ye.G. (1981) Ecological Essence of Cyclic Forest Dynamics. *Ekologia*, No.9, p.46-53.
- Korshunov, V.A. 1985. Age structure and specifics of forest formation in Far Eastern Ash stand. In: Utilization and Reproduction of Far Eastern Forest Resources. Theses of Analysis of Tree Cenosis Structure. Novosibirsk: Science Publ. p.50-70 (in Russian).
- Korzukhin, M.D. 1980. Age dynamics in a population of strongly-edifying trees. In: Problems of Ecological Monitoring and Ecosystem Simulation. Leningrad: Gidrometeoizdat Publ. v.3, p.162-178 (in Russian).
- Korzukhin, M.D. 1986. On the ecophysiological model of forest dynamics. In: Problems of Ecological Monitoring and Ecosystem Simulation. Leningrad: Gidrometeoizdat Publ., v.9, p.259-276 (in Russian).
- Korzukhin, M.D., and M.T. Ter-Mikaelyan. 1982. Competition for light and dynamics of model trees independently distributed on surface. In: Problems of Ecological Monitoring and Eco-system Simulation. Leningrad: Gidrometeoizdat Publ., v.5, p.242-248 (in Russian).
- Korzukhin, M.D., V.N. Sedykh, and M.T. Ter-Mikaelyan. 1987. Formulation of a forecast model of forest reproduction-age dynamics. Proc. Siberian Branch Acad. Sci., v.3, no.20, p.58-67 (in Russian).
- Korzukhin, M.D., V.N. Sedykh, and M.T. Ter-Mikaelyan. 1988. Application of forecast model of reproduction-age dynamics to Siberian-Pine stands in Central Ob Region. *ibid ser. biol.*, v.3, no.20, p.34-44 (in Russian).
- Kozin, Ye.K. 1982. On Cyclicity of Virgin-Forest Development in Sikhote Alin. Moscow: Forest Sci., No.3, p.24-31 (in Russian).
- Krauklis, A.A. and Ye.P. Bessolitsyna. 1980. Succession-Age Turnovers of Taiga Biogeocenoses. In: Study of Taiga Geosystems. Irkutsk: Geography Inst. of Siberian Branch Acad, Sci. Edition. p.37-71.
- Larher, V. 1978. Ecology of Plants. Moscow: World Publ. (in Russian).
- Larson, B.C. and C.D. Oliver. 1979. Forest dynamics and fuelwood supply of the Stehekin Valley, Washington. Proceedings of the Conf of Sci. Res. in the National Parks (2d), San Francisco, CA. US Dept. of Interior, Park Service, v.10, p.276-292.
- Leak, W.B. 1975. Age distribution in Virgin Red Spruce and Northern Hardwoods. *Ecology*. v.56, no.6, p.1451-1454.
- Mäkelä, A. 1986. A new model of stand growth using pipe theory. *J. Theory Biol.* v.43, no.3, p.322-334.
- Manko, Yu.I. 1967. Abies-Picea stands in Northern Sikhote Alin. Leningrad: Science Publ. (in Russian).
- Mitchell, K.J. 1969. Simulation of the growth of even-aged stands of White Spruce. *Yale Univ. Bull.* no.75.
- Mitchell, K.J. 1975. Dynamics and simulated yield of Douglas-Fir. *Forest Sci. Monog.* v.17, p.1-39.
- Moiseenko, S.N. 1963. Age structure of Siberian-pine-deciduous forests. Vladivostok: Works of Far East Forest Inst. v.5, p.12-26 (in Russian).
- Molchanov, A.A. 1971. Productivity of organic Mass in various forests. Moscow: Science Publ. (in Russian).

- Moloney, K.A. 1986. Wave and non-wave regeneration process in a Subalpine *Abies Balsamea* Forest. *Can. J. Bot.* v.64, p.341-349.
- Monserud, R.A. 1976. Simulation of forest tree mortality. *For.Sci.* v.22, no.4, p.438-444.
- Newnham, R.M. and J.M.P. Smith. 1964. Development and testing of stands models for Douglas-Fir and Lodgepole Pine. *For. Cron.* v 40, no.4, p.494-502.
- Oliver, C.D. 1978. The development of northern Red Oak in mixed species stands in Central New England. *Yale Univ. School of Forestry and Environmental Studies Bulletin*, no.91.
- Oliver, C.D. 1981. Forest development in North America following major disturbances. *For. Ecol. and Manag.*, v.3, p.153-168.
- Oshima, Y., M. Kimura, H. Iwaki, and S. Kuriora. 1958. Ecological and physiological studies on vegetation of Mt. Shimigare. Preliminary Survey of the Vegetation of Mt. Shimigare. *Bot. Mag.*, v.71, p.289-300.
- Payette, S. 1987. Recent porcupine expansion at tree line: a dendroecological analysis. *Can. J. Zool.* v.65, no.3, p.551-557.
- Polikarpov, N.P. 1976. Complex studies in mountain forests of the Western Sayan. In: *Problems of Forest Science*. Krasnoyarsk: Siberian Branch Ac. Sci. Publ. v1, p.26-79 (in Russian).
- Razumovsky, S.M. 1981. Trends of ecosystem dynamics. Moscow: Science Publ. (in Russian).
- Reiners, W.A. and G.E. Lang. 1979. Vegetational patterns and process in the Balsam Fir Zone, White Mountains, New Hampshire. *Ecology*. v.60, no.2, p.403-417.
- Ross M.S., T.L. Sharik, and D.W. Smith. 1982. Age structure relationships of tree species in an Appalachian Oak Forest in Southwest Virginia. *Bulletin Torrey Bot. Club.* v.109, no.3, p.287-288.
- Rozenberg, V.A., Yu.I. Manko, and N.G. Vasiliev. 1972. Main specifics of deployment and dynamics of forests in Primorye and the Amur Region. Sverdlovsk: Works of Animal and Plant Ecol. Inst. Ac. Sci. v.84, p.116-123 (in Russian).
- Sabitov, R.H. 1977. Reproduction of Siberian Pines in burnouts in mountain forests of the Northern Urals. Sverdlovsk: *ibid.* v.105. p.129-135.
- Sedykh, V.N. 1979. Formation of Siberian-Pine stands in the Ob Region. Novosibirsk: Science Publ. (in Russian)
- Semechkin, I.V. 1970. Dynamics of stand age structure and relevant methods of investigation. Krasnoyarsk: *Questions of Forest Sci.* v.1, p.422-445 (in Russian).
- Shugart, H.H. 1984. A theory of forest dynamics. New York: Springer-Verlag.
- Smirnov, V.A. 1971. Organic mass in several forest phytocenoses in European USSR. Moscow: Science Publ. (in Russian).
- Smolonogov, Ye.P. 1970. Age dynamics and economy-selective cutting of deciduous-dark coniferous forests in the water- preserve strip along the Ufra River in Sverdlovsk Oblast. Sverdlovsk: Works of Animal and Plant Ecology Inst. Ac.Sci. v.77, p.117-134 (in Russian).
- Sprugel, D.G. 1976. Dynamic structure of wave-regenerated *Abies Balsamea* Forests in the Northern-Eastern United States. *J. Ecol.*, v.64, p.889-991.
- Structure and Product**
- Stubblefield, G.W., and C.D. Oliver. 1978. Growth of a mixed red alder - hemlock - red cedar - douglas fir stand and its silvicultural implications.

- Sukachev, V.N. and G.I. Poplavskaya. 1927. Flora of the Crimea State Preserve. In: Crimean State Preserve: Its Nature, History, Significance. Moscow: Central Science Publ. p.145-171 (in Russian).
- Vasiliev, N.G., and Kolesnikov, B.P. 1962. Black-Fir-Deciduous Forests in South Far East. In: Proceedings Far East Branch Acad. Sci. Series Biol. v.8, no.10. (in Russian).
- Watt, A.S. 1947. Pattern and process in the plant community. *J. Ecol.* v.35, p.1-22.
- Zubarev, V.M. 1965. Structure of Siberian Pine stands and cutability. Moscow: Forest Economy Publ. no.11, p.3-10 (in Russian).
- Zyabchenko, S.S. 1982. Age dynamics of pine stands in the European North. Moscow: Forest Sci. no.2, p.3-10 (in Russian).