



Guidelines and Protocols for Monitoring Riparian Forest Restoration Projects

New Mexico Forest and Watershed Restoration Institute

Guidelines and Protocols for Monitoring Riparian Forest Restoration Projects

Researched and prepared by Krista Bonfantine, Arid Land Innovation, LLC,
Joe Zebrowski, New Mexico Forest and Watershed Restoration Institute,
and Andrew Egan, New Mexico Forest and Watershed Restoration Institute.

NEW MEXICO 
FOREST AND WATERSHED
RESTORATION INSTITUTE
AT NEW MEXICO HIGHLANDS UNIVERSITY



Acknowledgments

The authors wish to thank the following individuals for their assistance in the preparation and review of this document:

- David Dreesen, Agronomist, USDA-NRCS Plant Materials Center
- Eytan Krasilovsky, Community Forestry Coordinator, Forest Guild
- Colin Lee, Ecologist, Kewa Tribe
- Kent Reid, Forester, New Mexico Forest and Watershed Restoration Institute
- Jack Triepke, Regional Ecologist / Air Program Manager, U. S. Forest Service Southwestern Region
- Cheryl Zebrowski, Assistant Librarian, New Mexico Highlands University

The opinions, findings and conclusions or recommendations expressed in this document are those of the authors and do not necessarily reflect the views of the reviewers or their organizations.

Citation

Bonfantine, K., J. Zebrowski, and A. Egan. 2011. Guidelines and protocols for monitoring riparian forest restoration projects. A publication of the New Mexico Forest and Watershed Restoration Institute. Available at: www.nmfwri.org.

Copyright

New Mexico Forest and Watershed Restoration Institute, New Mexico Highlands University.

This handbook is part of the CFRP Multiparty Monitoring Handbook Series. Several other handbooks that provide additional, detailed information on the multiparty monitoring process are available at www.nmfwri.org and www.fs.fed.us/r3/spf/cfrp/monitoring.

Unless otherwise attributed, all photos in this document were taken by Krista Bonfantine, Arid Land Innovation, LLC.



Photo: Sean Weaver

Contents

Forward	4
Introduction	8
Riparian Ecology and Restoration Overview	9
A Brief Review of Riparian Ecology	9
What is Restoration?	10
Riparian Monitoring	11
Developing a Monitoring Plan	11
WHY: Why should we monitor?	11
WHAT: What should we monitor?	11
HOW: How should we monitor?	13
Field Measurements	18
Establishing and Marking Out the Plot Area	18
Measuring the Ecological Indicators on Each Plot	18
Measurements Recorded at Plot Center	19
Measurements Recorded Within the Small Plot	20
Measurements Recorded Within the Large Plot	23
Measurements Recorded Across Project Area	28
Depth to Groundwater	28
Soil Salinity and Texture	29
Summarizing the data	32
Wrapping up the Monitoring Project	36
Literature Cited	37
Appendices	
Appendix 1. Additional monitoring information resources	41
Appendix 2. Instructions for installing shallow groundwater wells	42
Appendix 3. Sample Data Collection Sheets	45
Appendix 4. Tree Diameter and Height Measurements	50

Introduction

The centuries-long transformation of the valley bottoms and floodplains of the southwestern United States into urban and agricultural centers has dramatically altered the hydrology and vegetation of the region's riparian ecosystems. Due to river impoundment, urbanization, agricultural conversion, and hydrologic and ecological changes, the historic condition may no longer represent a realistic desired future condition within the context of riparian restoration activities.

Early settlement in New Mexico, for example, centered on watercourses and, as a result, many municipalities in the state contain riparian ecosystems. Often in these areas, native vegetation has declined while exotic species have invaded and matured, thereby affecting the loading and pattern of the riparian fuel complex. Instead of the human community growing into the forest and creating the wildland urban interface, the interface has grown up within the urban area. Protecting communities from the sometimes intense, fast moving fires that occur within these corridors is an important public safety issue for many local communities.

Fuel reduction is a primary management objective for treating western riparian areas on USFS land (Stone et al. 2010) and riparian sites are frequently identified as priority areas for hazardous fuels reduction in community wildfire protection plans. Unfortunately, there is little science available to guide the fuel management process. Riparian areas, despite their ecological importance, have been poorly studied with regard to fire and fuel dynamics. The historic fire regime, vegetation, and fuel conditions are largely unknown. Also lacking are any long-term data comparing the ecological impacts of various treatments (Dwire and Kauffman 2003; Stone et al. 2010). Well-designed monitoring of riparian projects is critical to improving current treatments and modifying future techniques.

This handbook offers guidelines and protocols for monitoring riparian restoration projects. Protocols are derived from the synthesis of a broad range of existing literature on the assessment of riparian fuels, vegetation, and wildlife habitat into a methodology that is efficient, objective, and appropriate for quantitative summaries. These guidelines are also informed by the experiences of the staff of the New Mexico Forest and Watershed Restoration Institute and its partners and stakeholders. Additional resources are also suggested for measuring variables such as hydrology, water quality, and aquatic habitat. While recent work has focused on the development of socioeconomic indicators for restoration projects (Egan and Estrada-Bustillo 2011), the focus of this handbook is the monitoring of ecological dimensions of riparian restoration. In addition, rather than creating new monitoring protocols, this document combines existing protocols to provide guidance for monitoring riparian projects within, but not limited to, New Mexico's Collaborative Forest Restoration Program (CFRP). Indeed, monitoring is an activity that is increasingly used to evaluate the function of riparian systems, allowing landowners and resource managers to make informed decisions. The guidance presented here is likely to evolve over time as research progresses.



Riparian Ecology and Restoration Overview

A Brief Review of Riparian Ecology

Riparian areas are defined as the interface between terrestrial and aquatic ecosystems, with boundaries extending outward to the limits of flooding and upward into the canopy of streamside vegetation (Gregory 1991), including streams, lakes, bays and their adjacent side channels, floodplains, and wetlands. In the arid Southwest, it is helpful to define “riparian” as the vegetation associated with drainage systems because riparian vegetation occurs along ephemeral water features as well as perennial systems (Dick-Peddie 1993). Although “riparian” and “wetland” are used interchangeably in some contexts, they are defined separately in others. The precise wording is important with regard to regulatory definitions that might affect project planning and permitting requirements. For the purposes of this document, “riparian” will be used generally to describe all streamside vegetation and “wetlands” will refer only to aquatic systems with emergent and submergent vegetation (Dick-Peddie 1993). In addition, the term “bosque” has been used to describe gallery forests found in riparian flood plains of the southwestern United States. For the purposes of these restoration monitoring guidelines, we consider the bosque to be a specific type of riparian ecosystem and thus use the term sparingly, preferring the more inclusive riparian forest or riparian ecosystem.

Riparian ecosystems are biodiversity hot spots in the southwestern United States. Riparian areas also provide opportunities for recreation, the enhancement of a landscape’s aesthetic values, and the improvement of water quality and quantity. Riparian ecosystems are of particular importance to many Native American communities, many of which are located in predominantly riparian areas that contain important cultural, agricultural, and ecological resources.

Every ecosystem exists in a dynamic equilibrium maintained by a

natural disturbance regime. “Disturbance” is defined as,

“A relatively discrete event in time that disrupts ecosystems, communities, or populations, changes substrates and resource availability, and creates opportunities for new individuals or colonies to become established.” (Smith 1992)

Historically, riparian ecosystems in the Southwest were dynamic, frequently transformed by the power of water through seasonal flooding and resulting movement of debris, vegetation, and sediment. This disturbance maintained both landscape and species diversity. Now that the power of the water has largely been removed or modified, it no longer acts as the primary agent of disturbance in many riparian systems.

By damming, diverting, and dewatering the region’s river systems through groundwater extraction, humans have made the floodplain habitable and agriculture successful in the region. However, these achievements have permanently altered the region’s riparian ecosystems. Species adapted to massive floods, shifting substrate, and periodically saturated soil now cope with dry soil, a disconnected water table, and a lack of flooding. The lack of flooding and inundation has impacted not only moisture availability but also seed dispersal patterns, recruitment, and nutrient cycling. Many floodplains are now high and dry, suspended above the adjacent channel, deprived of the valuable sediment inputs brought by floods, and choked by the tree and shrub litter no longer carried away. Salt that naturally accumulates on the soil surface as groundwater wicks upward and evaporates and is no longer flushed by flood water. In many cases, these alterations have created conditions more suitable for colonization by generalist exotic species than for native specialists.

Riparian plant communities are often dominated by a category of plants known as phreatophytes. This term simply refers to plants that obtain water from the water table or the layer of soil



just above the water table. Natives such as cottonwoods and willows are obligate phreatophytes. Obligate phreatophytes require access to the water table for survival. In contrast, tamarisk (*Tamarix* spp.), also known as saltcedar, is considered a facultative phreatophyte. As a facultative species, tamarisk will utilize water table when available but it can also extract water from drier soil than many natives or can obtain water from pockets of moisture (can obtain water at lower plant water potentials). It does not require continual groundwater contact. It can also do more with less (higher water use efficiency), making it a highly successful and abundant colonizer of the new, flood-free riparian ecosystem. As sites dry out, native plant communities often fail to regenerate, and are replaced by tamarisk/saltcedar (*Tamarix* spp.), Russian olive (*Elaeagnus angustifolia*), or Siberian elm (*Ulmus pumila*). In many cases, the exotics are better suited to the current conditions, able to out-compete natives, and difficult to eradicate.

In addition to higher plant diversity, riparian vegetation is characterized by greater biomass, stocking, stand density, and rates of production than adjacent upland vegetation (Stone et al. 2010). These factors mean that there is generally more fuel available in riparian ecosystems, although it may only burn under extreme conditions. The presence of tamarisk in a stand can further increase the total fuel

“On upland areas, site characteristics, such as overall climate and general landscape and soil features, normally remain relatively stable over time. One can select an appropriate monitoring site and be relatively confident that most changes in the vegetation on that area, over time, can be related to whatever management is being applied. However, in riparian areas there often is a continual process of change. One must use caution in accounting for vegetation changes caused by naturally occurring site changes compared to changes due to specific management activities.” (Winward, 2000, p. 5)

loading for a site. Tamarisk more rapidly produces a larger volume of flammable fuel, both living and dead, than native communities dominated by Fremont cottonwood (*Populus fremontii*) (Finch 2003).

What is Restoration?

The U.S. Forest Service Manual 2000 defines ecological restoration as,

“The process of assisting the recovery of resilience and adaptive capacity of ecosystems that have been degraded, damaged, or destroyed. Restoration focuses on establishing the composition, structure, pattern, and ecological processes necessary to make terrestrial and aquatic ecosystems sustainable, resilient, and healthy under current and future conditions.” (USFS 2010a)

Riparian restoration projects are unique because, in many cases, a fundamental ecological disturbance process, flooding, cannot be returned to the system. This has led some practitioners to adopt the term “rehabilitation” or “repair” rather than “restoration” to describe these projects (Society for Ecological Restoration International Science & Policy Working Group, 2004). Projects whose primary goal is fuel reduction may be difficult to define as restoration efforts because the preservation of ecosystem composition and structure may be limited.

Restoration activities may include removal of nonnative species, thinning for fuels reduction and habitat improvement, and planting and reseeded of desirable native vegetation. Planting and reseeded are particularly common in projects that involve removal of nonnative phreatophytes. Vegetative restoration is often accompanied by other nonvegetative restoration activities designed to control erosion, stabilize stream banks, or other measures designed to improve the hydrologic function of the riparian area.

Whether through restoration or rehabilitation, the benefits of improved riparian ecosystems extend far beyond the project footprint. Approximately two thirds of all bird species in the Southwest depend on riparian ecosystems for at least part of their lives (Johnson 1977) and approximately 80 percent of all sensitive vertebrate species in New Mexico depend upon riparian or aquatic habitats at some time during their life cycle (NMDGF 2000). Since so many birds and sensitive vertebrate species depend on this ecosystem, significant changes to these systems in the name of fuels reduction or restoration should proceed cautiously.

See New Mexico Forest Restoration Series Working Paper 1, Short Guide for Developing Collaborative Forest Restoration Project Restoration Prescriptions, (Savage et al. 2008) for a more in-depth discussion of restoration treatments.

Riparian Monitoring

Numerous procedures and protocols for riparian monitoring have been developed by a multitude of agencies and other entities. The guidelines presented here were developed specifically for Collaborative Forest Restoration Program riparian projects; however, if appropriate, they can be applied to other projects. These guidelines cover indicators that should be strongly considered when monitoring any CFRP riparian project. The project's multiparty monitoring team may direct that additional indicators be observed. Furthermore, the multiparty monitoring team may direct that different protocols or modifications to these protocols be used, depending on circumstances specific to the project.

Regardless of the specific monitoring protocols used, all monitoring projects include a planning phase, a data collection phase, and a data summary phase. Depending on the nature and scope of the project, some of these phases may be concurrent.

Developing a Monitoring Plan

Identification of specific project objectives and available resources are fundamental to any inventory or monitoring project. Monitoring must be based on an understanding of what should be monitored and why. With a full understanding of the purpose of the monitoring and the indicators to be measured, a plan can be developed that identifies how the monitoring will be accomplished.

WHY: Why should we monitor?

Monitoring has always been an important component of restoration projects – including those funded by the CFRP – because it helps to assess whether the objectives of the restoration project have been met and the effectiveness of the activities implemented on the ground. In addition, monitoring serves a higher purpose on riparian restoration projects because there is little published research on the necessity for or ecological effects of fuel reduction treatments in riparian ecosystems (Stone et al. 2010). Monitoring essentially aims to measure change over time. By measuring the trajectory of ecological



attributes land managers can assess the impacts of project activities, adjust activities if necessary (adaptive management) and improve future restoration efforts. Although monitoring can be expensive and time-consuming, it is fundamental to improving our understanding of potential impacts of project actions on the habitat and populations of target species. Well-designed monitoring that quantifies the effects of riparian treatments on fuel loads, fire risk, and ecological effects is needed to provide a scientific-basis for the continued implementation of restoration treatments (Stone et al. 2010).

WHAT: What should we monitor?

Riparian restoration projects involve a suite of biotic and abiotic factors that are often not considered in upland ecosystems. These factors include soil moisture dynamics, hydrogeology, nutrient cycling, and groundwater connectivity. In many cases, that means that a broader group of individuals with a wider range of expertise should be part of a riparian restoration multiparty monitoring team. Potential impacts on hydrology, geomorphology and threatened and endangered species may necessitate participation from many resource specialists and monitoring additional variables in riparian systems may be helpful in explaining observed changes. However, time and personnel are always limited and more disciplines at the table means more variables to monitor. Several techniques have been developed that incorporate a broad range of parameters to evaluate the condition and functionality of riparian ecosystems. While basic guidelines for monitoring riparian restoration projects are offered here, a summary of additional protocols that may be helpful is provided in Appendix 1.

Although these guidelines focus on monitoring the ecological values associated with riparian areas and riparian restoration projects, the potential socioeconomic aspects of restoration activities in these ecosystems cannot be ignored. Indeed, riparian restoration often has as its principle objective the mitigation of severe wildfire and its impacts on public safety. Riparian area monitoring practitioners should refer to the socioeconomic restoration monitoring protocols recently developed by the New Mexico Forest and Watershed Restoration Institute for guidance on ways to assess these important aspects of restoration monitoring (Egan and Estrada-Bustillo 2011).

The CFRP requires monitoring of six ecological indicators for all projects with on-the-ground treatment. The following descriptions of those indicators are taken from Multiparty Monitoring and



When non-native species make up a large part of the stand, the volume of mulch produced by a mastication treatment or on-site chipping may exceed the volume that meets fire hazard reduction and ecological objectives. Mulch depths exceeding four inches are generally considered to be undesirable. In forest types containing timber species such as ponderosa pine, the volume of mulch that will be produced by a project can be estimated by applying a biomass equation to the pre-treatment tree data. Unfortunately, as non-timber species, no such equations exist for riparian trees. Although there is currently no method for precisely calculating the amount of residue that will be produced, it is worth considering the gross volume of standing biomass to be cut and evaluating whether some removal of material may be necessary.

Assessment of Collaborative Forest Restoration Projects - Short Guide for Grant Recipients (Moote et al. 2009):

Live and Dead Tree Density. Tree density is an estimate of how many trees there are per area in the forest. It is valuable information for restoration work, since many sites have a much higher density of trees than would be considered natural in southwestern forests. The majority of these abundant small trees are growing very slowly because of competition for light and water. Bosque forests usually have high densities of non-native trees. Many small trees serve as ladder fuel to carry fire into the crown of mature trees. Snags, or dead standing trees, make good wildlife habitat, are often scarce in the forest, and should be protected during treatments.

Live and Dead Tree Size. Tree size, like density, is an important indicator of vulnerability to crown fire. Large trees in forests where fires used to be frequent are relatively safe from prescribed fires. Small trees, however, can carry fire into the canopy, where it can destroy the forest. Large dead standing trees, or snags, provide habitat for wildlife and some should be protected. Since many small trees are cut in restoration treatments, while old and large trees are protected, the average size of trees should increase after treatments.

Crown Base Height. Crown base height (CBH) is the distance between the ground and the lowest live branches in the crown of a tree. This indicator is important to determine the likelihood for surface fire to move into the tree canopy. CBH for individual trees are then averaged to determine the crown base height for the area sampled. Since many small trees will be cut in restoration treatments, average CBH for a stand usually increases. An increase in CBH can represent a reduced fire risk.

Overstory Canopy Cover. Overstory canopy cover is a measure of the amount of leaves or needles in tree branches overhead. If the overstory canopy cover is very dense, it means that tree crowns are close together and are likely to carry an intense fire from tree crown to tree crown. When the canopy is more open, there is more space between tree crowns and the forest is safer from crown fires. Also, a more open canopy means that more sunlight reaches the forest floor, allowing a healthy understory of grasses and forbs to grow. However, some level of canopy cover is good for wildlife habitat, especially when large trees are left in clumps. Since restoration treatment removes trees, percent overstory canopy cover is expected to decrease.

Understory Cover. The understory of grass and small plants under the forest canopy is a good indicator of forest health. The understory has many ecological functions, including providing habitat for wildlife, protecting soil from erosion, and carrying low-intensity fires. Where trees have an unnaturally high density, the plant cover on the ground is usually sparse. Thinning the trees results in an increase in understory plant cover over time, but a substantial recovery may take some years.

Surface Fuels. Because surface fuels like logs and branches can burn hot and carry fires into tree crowns, the amount of dead and down surface fuels is an important measure of how vulnerable the forest is to crown fire. In ponderosa forests that historically had frequent, cool surface fires, hot crown fires were very unusual. In the bosque, nonnative trees can produce large amounts of dead and down wood that increase the risk of crown fire. The reduction of surface fuels is an important restoration goal. However, it is wise to leave some dead and down wood on the ground to foster wildlife and understory growth.

When monitoring riparian restoration projects, four additional indicators should be considered:

Vegetative Community Structure. Vegetation community structure is an important component of riparian wildlife habitat. Structure classifications are based on the amount of vegetation at different layers of the canopy. Community structure types were developed by Hink and Ohmart (1984) to describe patterns of vegetation communities along the middle Rio Grande (Table 3; page 20). Although the composition of species will differ for other systems, the structure classes and height cutoffs can still be applied. Generally speaking, greater structural diversity is associated with greater wildlife diversity.

Depth to Water Table. It is important to monitor the depth to the water table and soil properties in order to set reasonable expectations for a restoration project. As discussed in the Riparian Ecology section, the current hydrology of a site can be very different from the historical condition. By measuring the depth to groundwater, the manager can determine what portion of the project area should be considered a riparian area and what portion should be treated as an upland site. When nonnative phreatophytes dominate a site, their removal is often followed with seeding or planting of native species. Determining what plant species and stock type is appropriate for a revegetating a site requires an understanding of site hydrology so that sites are revegetated with appropriate species that are able to succeed.



Soil Salinity. When a project involves revegetation, soil properties should also be measured. Saline soil in riparian ecosystems can affect the soil-water balance and limit the range of species suitable for the site. Salts can accumulate at the soil surface as water evaporates from bare soil. Salt-affected soil is also common where tamarisk dominates because salt accumulates in tamarisk leaves and is deposited on the soil surface with the leaf litter.

Soil Texture. Soil texture class is related to weathering and parent material. Clay soil stores water differently than sandy soil. This can be a factor in appropriate species selection because some plant species are tolerant of a wide range of soil textures and others are more specific. Soil texture also influences aeration, which, in turn, influences microbial activity, nutrient availability, and plant root growth (Walters et al. 1992). Simple measurements of soil texture can be performed in the field and provide another piece of the revegetation puzzle.

HOW: How should we monitor?

Once the indicators and conditions to be monitored are established, a site map of the project area should be prepared. The site

should be stratified into similar units and a sampling plot placement scheme and a plot layout design should be developed. Geographic information systems (GIS) technology can be a great help to this aspect of planning. Grantees without GIS capability should seek out partners or consultants who have the capability to assist with various mapping aspects of project planning and management.

Basic considerations for planning any inventory or monitoring effort include:

- Preproject familiarity with the project area;
- Where appropriate, consideration of sampling errors consistent with the project's targeted allowable errors, and the elimination of measurement error;
- Adequate sampling intensities to achieve project objectives; and
- Representative sampling of the project area, including consideration of edge effect bias – the bias associated with not accounting for the edges of project areas when locating sample points.

Husch et al. (2002) and Avery and Burkhart (2002) provide good overviews of sampling error considerations.

Creating a Site Map

Riparian restoration projects tend to be relatively small in size. However, riparian ecosystems are often diverse and composed of a mosaic of several vegetation communities. Because of the complexity of riparian monitoring, a critical first step is the creation of a detailed site map. The map will indicate the basic cultural and natural features and indicate the structure and composition of the vegetation. It will also serve as the basis for stratifying the project area into similar vegetative units and provide the framework for planning the location of the sampling sites.

In mapping a project area, it is best to start with aerial images of the area, the more detailed the better. Although low-level, high-resolution aerial photography is ideal, base maps can also be created using USGS quads or free computer tools such as Google Earth. Hydrologic features, structural elements, and distinct vegetation patches can be delineated in the office.

A hard-copy base map and a GPS unit should be used during field reconnaissance and the collection of baseline data. During this initial phase of field work, detailed observations are important in order to accurately characterize current conditions and define the desired future conditions for each stratified area. Observations may be geographically referenced using the GPS unit or simply drawn on the map. Spending some time on the front end observing site dynamics can go a long way to developing a successful restoration monitoring project. When conducting the site analysis, it's important to involve as many members of the multiparty monitoring team as possible and to map all relevant landmarks and obstacles, such as fence lines and jetty jacks.

Water features that should be noted include:

- Main stream channel, side channels, and ditches;
- Dry washes and gullies; and
- Surface water at the site and whether it is standing or flowing.

If standing surface water is present, it may also be helpful to measure and record the depth, length, and width of this area to detect changes and/or accurately map the site. Consulting river gauge data will help to define the relationship between the standing water and high flow periods. This information coupled with multiple site visits will help to determine the length of time that the site is usually inundated each year. The average period of inundation is an important parameter in selecting appropriate plant species for revegetation. Long periods of soil saturation limit the growth and survival of woody riparian species, which generally require highly aerated soils. A restoration site with a long period of inundation may be more successfully treated as a wet meadow and planted with appropriate herbaceous species. Keep in mind that, in areas where beaver are present, inundation may be a dynamic process which is difficult to predict from one year to the next.

As with any inventory, it is important to walk the entire project area and sketch out areas of different species composition and/or density of vegetation, noting any obvious differences in soil moisture or

texture. Although access may be difficult where dense stands of salt cedar or Russian olive are present, it's essential to explore as much of the area as possible, identifying and sketching major vegetation communities across the site. If identified, important microhabitats such as wetlands can be avoided by heavy equipment or herbicide application. Other important observations include:

- Identification of plant species, collecting samples of any species that are abundant for later identification;
- Presence of exotic species; and
- Hydrologic clues from plants. For example, cattails, willows, or herbaceous species such as meadow fescue that require wet soil; xeric species such as four-wing saltbush and prickly pear; and species such as four-wing saltbush, saltgrass, and switch-

grass that may indicate saline or moderately saline soil (Howard 2003; Hauser 2006; Uchytel 1993).

Stratifying the project area

The base map forms the basis for stratifying the project area into similar units for monitoring, reducing sampling errors and increasing precision of the sampling effort. Strata may be based on vegetation, soil type, management and current status (Herrick et al. 2005). The strata may also be useful in describing treatment areas. For instance, techniques for



the removal of nonnative phreatophytes may differ depending on the presence of native tree and shrub species in the stand. Although stratification can improve the precision of an inventory, a large number of strata can also fragment sample sizes. As a result, any increase in the number of strata may result in an increase in the number of sample units required. However, if the variability of key attributes can be estimated before the inventory, the appropriate number of plots will be established given the objectives of the inventory, which could result in the measurement of fewer sample plots (Egan 2011).

The Monitoring Manual for Grassland, Shrubland, and Savanna Ecosystems, Volume II (Herrick et al. 2005; p. 13) provides a good discussion of stratifying land into monitoring units.

Locating Plots

Objective sampling ensures that the data collected are both unbiased and representative of the unit being measured.

Systematic Plot Placement

There are a number of different ways to objectively place plots within the project area according to some sort of pattern (Figure 2, Page 18). By one method, a network of plots on a grid can be placed on the map manually or by using a regular point generator in ArcGIS, such as Hawth's Tools (now Geospatial Modeling Environment, available at www.spatial ecology.com). Plot centers that fall on or very near a project unit boundary are sometimes offset into the project area by a distance that will allow the entire plot to fall within the project area. However, to account for the bias sometimes associated with boundary overlap, a mirage method for plot location should be considered (Avery and Burkhart 2002).

Another systematic way to locate plots on the landscape is to position them at some set distance from a fixed feature such as a road or

Ohkay Owingeh CFRP Project

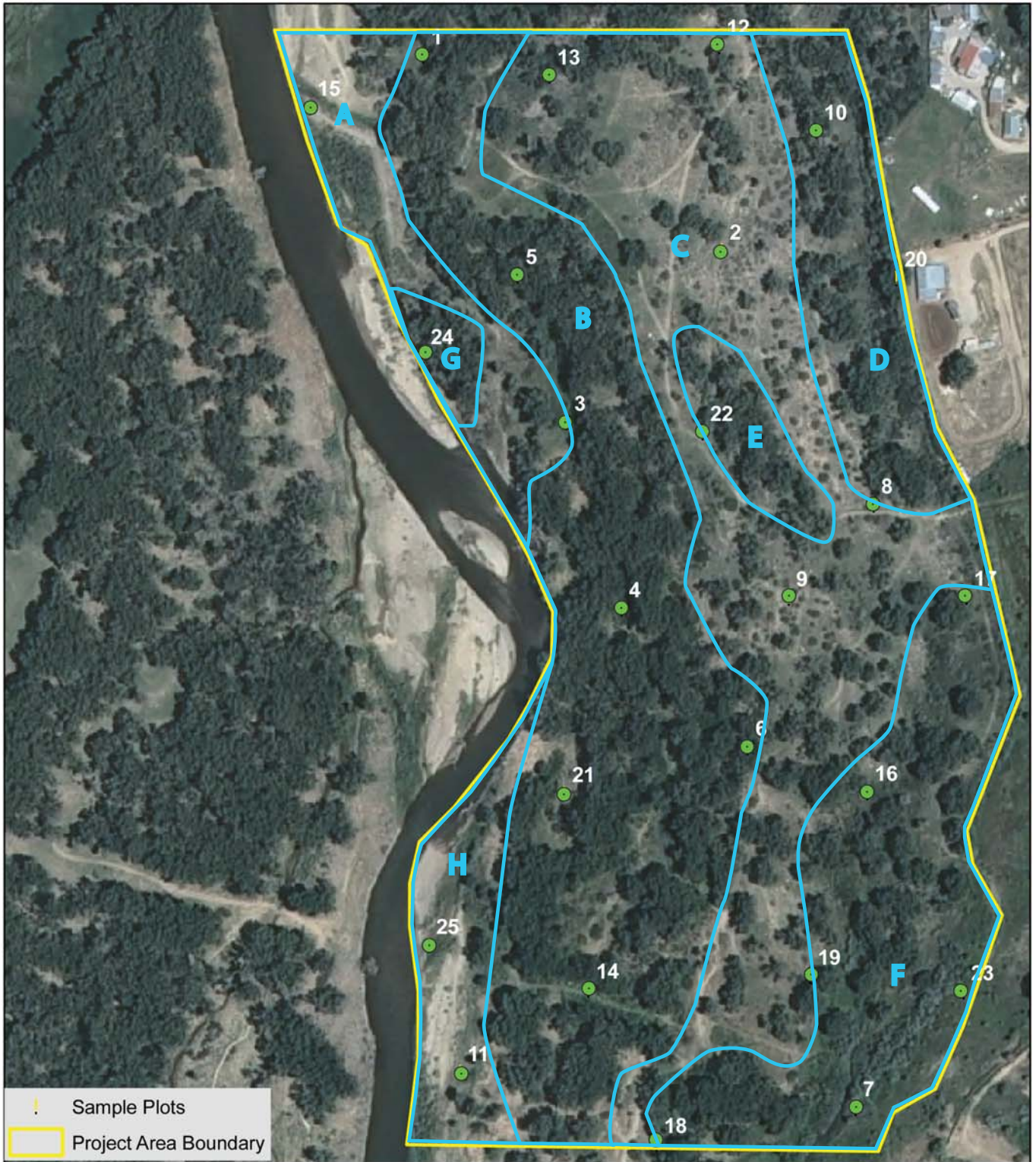

Sources:
 Points: NMFWR, Feb - Mar 2011.
 Transects: Riparian Forest Restoration in San Juan Pueblo and Española, CFRP Project 03-DG-11031000-008, Project Close Out Report, La Calandria Associates, Inc., 2006.
 Image: 2009 USDA Santa Fe County Mosaic downloaded from <http://rgis.unm.edu/>, Dec 11, 2009.

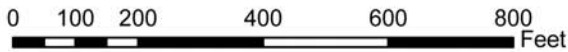

The tolerance of plant species for saturated or dry soil conditions exists on a continuum. Most plant species in the United States are assigned a wetland indicator status. The wetland indicator status (Table 1) categorizes plant species according to the likelihood of their occurring in wetlands. Species are classified at the national and regional level. New Mexico is a part of Region 7 (Southwest), which also includes Arizona. An asterisk (*) may follow a regional indicator to identify tentative assignments based on limited information from which to determine the indicator status. The three facultative categories may be further subdivided by (+) and (-) symbols to indicate the regional frequency a plant may be expected to occur in wetlands. The wetland indicator status for each species can be found in the USDA Plants Database (www.plants.usda.gov).

TABLE 1. WETLAND INDICATOR STATUS DEFINITIONS

Indicator Code	Wetland Type	Comment
OBL	Obligate Wetland	Occurs almost always (estimated probability 99%) under natural conditions in wetlands.
FACW	Facultative Wetland	Usually occurs in wetlands (estimated probability 67%-99%), but occasionally found in non-wetlands.
FAC	Facultative	Equally likely to occur in wetlands or non-wetlands (estimated probability 34%-66%).
FACU	Facultative Upland	Usually occurs in non-wetlands (estimated probability 67%-99%), but occasionally found on wetlands (estimated probability 1%-33%).
UPL	Obligate Upland	Occurs in wetlands in another region, but occurs almost always (estimated probability 99%) under natural conditions in non-wetlands in the regions specified. If a species does not occur in wetlands in any region, it is not on the National List.
NA	No agreement	The regional panel was not able to reach a unanimous decision on this species.
NI	No indicator	Insufficient information was available to determine an indicator status.
NO	No occurrence	The species does not occur in that region.

In the following example, New Mexico olive is given the wetland indicator status of FAC+ in Region 8 (Intermountain) meaning that it is slightly more likely to occur in wetlands than non-wetlands. In Region 6 (South Plains) it is FAC- and slightly more likely to be found in non-wetlands. In New Mexico, it is FACU or facultative upland, and occurs more often in non-wetlands than in wetlands.

Wetland Indicator Status:

Forestiera pubescens Nutt. var. *pubescens*

Forestiera neomexicana

Nat. Ind.	Reg. 1	Reg. 2	Reg. 3	Reg. 4	Reg. 5	Reg. 6	Reg. 7	Reg. 8	Reg. 9	Reg. 0	Reg. A	Reg. C	Reg. H
FACU, FAC+	NO	NO	NO	NO	NO	FAC-	FACU	FAC+	NO	FAC	NO	NO	NO

TABLE 2.

Plot Size (acres)	Plot Radius (feet)
1/1000	3.7
1/500	5.3
1/300	6.8
1/250	7.4
1/200	8.3
1/100	11.8
1/50	16.7
1/20	26.3
1/10	37.2
1/4	58.9
1/2	83.3
1	117.1

FIGURE 1.

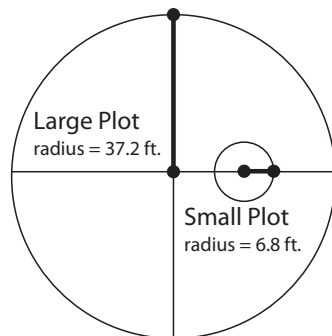

fence line. However, bias associated with nonrepresentative sampling across the study area and the intentional (versus random or systematic) location of sample plots must be accounted for. Similarly, sample units can also be placed perpendicular to major topographic and physiographic features such as contours, which allows investigators to capture attribute variability along inventory lines and more confidently use systematic, rather than strictly random, plot location methods.

One advantage of systematic plot placement is that the plot locations can be more easily reproduced if plot markers are destroyed or misplaced during the project.

Random Plot Placement

As an alternative, plots may be located randomly across the project area. Hawth's Tools for ArcGIS also contains a random point generator. After installing this extension, users are able to select parameters such as the number of plots desired, buffers from polygon boundaries, and stratification fields. Figure 3 on Page 18 is an example of random plot placement. As in the case of systematic

sampling, points that fall on or very near a project unit boundary are often offset into the project area by a distance that will allow the entire plot to fall within the project area. However, in order to minimize bias associated with boundary overlap, a form of the mirage method (Avery and Burkhardt 2002) is recommended

Labeling Plots

Regardless of how the random plot location is achieved, it is critical to develop a system for numbering plots at the outset of the project. Each plot should be assigned a unique tag to prevent confusion later. Systems such as numbering plots left to right, top to bottom, help to orient field personnel.

Designing the layout of the individual plots

Recommended plot layout

This handbook utilizes a nested fixed-area circular plot design based on the USFS Stand Exam (USFS 2010) and the BBIRD monitoring protocol (Martin et al. 1996). The BBIRD protocol was designed to provide information on habitat requirements for non-game bird species using standardized sampling protocols. Nested plots are sized to reflect the common frequency of the attributes measured. USFS Stand Exam guidelines for Region 3 recommend a 1/10th acre plot (radius = 37.2 feet) for riparian forest and woodland and riparian large shrubland. They also consider a 1/10th acre plot a good size for broad vegetation composition inventories. In this protocol, a large 1/10 acre plot will be used for trees. Within this large plot, a smaller plot is placed at an offset position following BBIRD (Figure 2). The small, 1/300 acre plot (radius = 6.8') is recommended for measuring regeneration, shrubs, ground cover, and, in some cases, surface fuels.

Although recommended plot sizes are included in the protocol, it may be necessary to adjust these sizes based on the density encountered in specific situations. A plot size appropriate for one species or attribute may not be appropriate for another. Resprouts may be far too numerous to count on a large plot and snags may be infrequent enough that they need a larger plot than that which might be appropriate for other attributes. One rule of thumb is that if the number of stems measured exceeds 100, the plot size should be decreased. On the other hand, if the plots seem to be missing attributes of interest, it may be necessary to either measure additional plots or increase the plot size. Table 2 provides a range of plot radii for different plot sizes. It can be helpful to use a plot size that can easily scaled to one acre. Plot radii can also be calculated using the area of a circle:

Area (ft²) = πr^2 where r = length of radius (feet). So,

$$r = \sqrt{\text{area}/\pi}$$

Circular plots have advantages over square or rectangular plots in that they are easier to establish and reinventory.

Alternative plot layouts

Depending on the type of vegetation, size of the project area, width of channel, project goals, and access issues, one plot layout approach may be better suited to a particular project than another. See Appendix 1 for a list of helpful monitoring resources but here are a few comments:

Greenline measurement

Some projects aim to monitor wetland vegetation changes along the water's edge or "greenline." Winward (2000) and Herrick et al. (2005) provide detailed instructions on assessing plant cover and species composition along the edge of the channel.

Sampling intensity. Among the questions associated with restoration monitoring is whether the inventory performed is providing information consistent with both landowner objectives and the anticipated use of inventory results. Meeting both objectives means balancing limited resources with the types of change that need to be detected. If the number of plots that need to be measured is set too high or too low, funding may be wasted or data gathered may be not be sufficient for drawing meaningful conclusions.

One approach to determining sampling intensity is to establish a set number of plots per acre. While this approach may work for some inventories on some sites and for some inventory objectives, it will not be appropriate for all site conditions or inventory situations, since it's not directly sensitive to the inherent variability associated with site and stand attributes being measured. In general, riparian ecosystems are more variable than upland sites and sampling requirements should be calculated based on available data whenever possible rather than simply assigning an arbitrary number of plots.

While there is flexibility associated with the most appropriate allowable error targeted for a given inventory project, in general the decision should include consideration of inventory objectives, end uses of the data, and the resources and expertise available to conduct the inventory.

The Monitoring Manual for Grassland, Shrubland, and Savanna Ecosystems. Volume II (Herrick et al. 2005; p. 142) and Egan (2011) provide guidance on sample size determination and a description of allowable error.

Point intercept transects

Point intercept transects, also known as line-point intercepts, provide an objective, accurate, and relatively quick method for measuring riparian plant species and cover. This method is becoming increasingly popular in riparian monitoring because it is less sensitive to placement, repeatability, geomorphic dynamics, and shape of riparian zone, and less prone to error associated with ocular estimates (Triepeke 2011). The method requires a small amount of equipment and little training to implement but it tends to underestimate rare species. The Monitoring Manual for Grassland, Shrubland, and Savanna Ecosystems. Volume I, (Herrick et al. 2005; p. 9) provides step by step instructions for performing this technique.

CFRP Transect/Quadrat Method

Winward (2000) suggests a series of transects perpendicular to the stream channel for measuring changes in cover of riparian vegetation clumps. The plot layout suggested by Moote et al. (2009) for monitoring CFRP projects can be used in riparian situations by placing transects perpendicular to the channel. This may work well in situations where the project area spans both sides of a wadeable stream channel. Detailed instructions are provided in Moote et al. (2009), but the following modifications may be helpful:

- Transect length should be based on the width of the riparian area. Transects should extend just beyond the current riparian vegetation in case the riparian area expands in size over time.

Ohkay Owingeh CFRP Project



FIGURE 2. SYSTEMATIC PLOT PLACEMENT

- More than the minimum recommended five transects may be required because sections of each transect, and the sampling points they contain, will fall in the channel.
- Quadrat measurements can include cover and density for shrub species and regeneration.
- In dense vegetation it can be difficult to layout the large square plots. Alternatively, circular plots could be used with plots centered on transect line. See Table 2 to determine the plot radii for a variety of common circular plot sizes.

Field Measurements

With the project area mapped and stratified, the sampling design complete, and the plot type determined, it is time to head to the field and collect data. A circular, fixed-radius plot is assumed. Most of the data are collected at individual plots; however, some information is collected across the entire project area, independent of the plots. All direction measurements used should be corrected for the local magnetic influence or attraction (declination) and the declination used recorded. If magnetic declination was not corrected, that fact should also be noted. An easy to use online magnetic declination calculator is available at www.ngdc.noaa.gov/geomag-models/Declination.jsp. When geographic locations are recorded, note the coordinate system and datum (e.g. geographic NAD 1983 or UTM Zone 13 NAD 1983). Record the date, time, and the names of the recorder and observers for each plot.

Establishing and Marking Out the Plot Area

Once a plot center location has been established, it should be designated with a marker that will reliably remain in place for at least the duration of the project. Plot locations must be geographically

Ohkay Owingeh CFRP Project

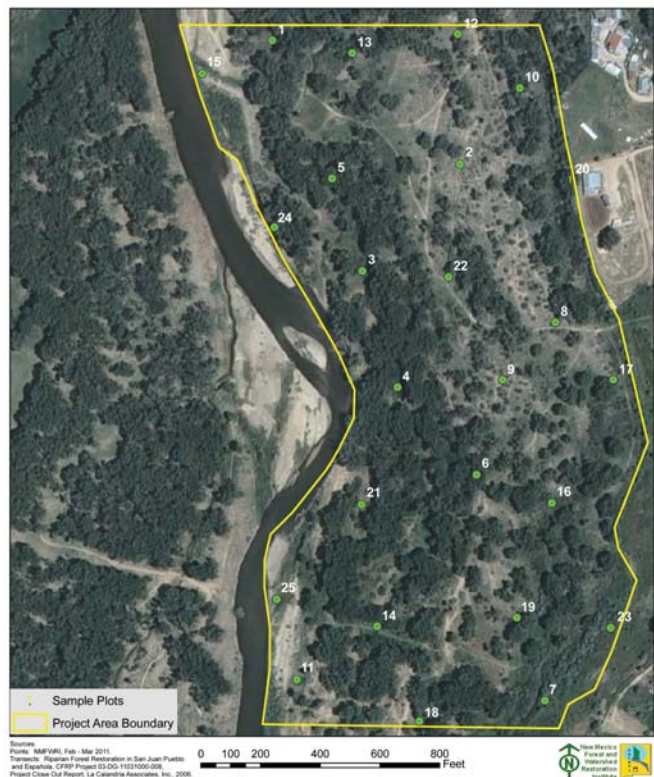

FIGURE 3. RANDOM PLOT PLACEMENT

referenced using a GPS unit and drawn on the map. If transects are used, record the coordinates of each end of each transect. Actual plot coordinates should be frequently downloaded from of the GPS unit and stored in a secure location to avoid loss of data. Detailed notes describing plot locations can also be helpful. Since many riparian projects involve mechanical fuel reduction, plot markers are frequently disturbed by heavy equipment. Rather than asking equipment operators to avoid plot locations, metal markers, survey nails, or rebar can be placed flush with the soil surface and, if necessary, relocated later using a hand-held metal detector.

The marker at plot center or a chaining pin can serve as an anchor for the measuring tape, which is extended out to 37.2 feet, or the large plot radius length, typically toward each cardinal direction. The tape is extended in this manner and flagging or pin flags are used to mark a few points along the large plot boundary.

The small plot is located in a position offset from the large plot center to reduce trampling effects on the surface vegetation (Martin et al. 1996). To locate plot center for the small plot, run the measuring tape from the large plot center due east. The small plot center point will be located at 15 feet along the measuring tape.

If Brown's transects are utilized for surface fuels measurements, the placement should be determined as the plot is established. Transects can either be placed due north and west from each plot center or in random directions, using a list of randomly generated azimuths. Regardless of the placement technique, the direction of each Brown transect should remain constant pre and post treatment.



FIGURE 3. EXAMPLE OF HINK AND OHMART STRUCTURAL VEGETATION TYPE V.

Measuring the Ecological Indicators on Each Plot

At each sample plot, measurements and observations will be made at the plot center, within the small plot, and across the entire large plot. Measurements and observations can be recorded in a field book or on locally developed datasheets. Appendix 2 contains blank examples of datasheets that may be used. Completeness, neatness, and legibility, though often difficult to attain in some field conditions, are essential to successful monitoring. Field time is wasted if the data cannot be adequately interpreted in the office.

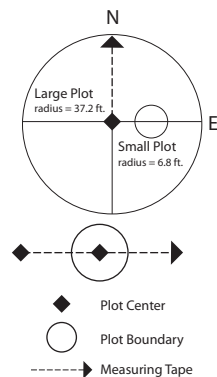

FIGURE 4.

Measurements Recorded at Plot Center

- Community structure
- Photos
- Overstory canopy cover

Community Structure

A structure type (I-VI) is assigned to each large plot. The structure class may be very clear such as a Type V area covered with a solid cover of shrubs and regeneration taller than a person (Figure 3, foreground). In other cases, it may be helpful to use the Structural Class Worksheet (Figure 5) to tally the amount and species present at different height layers. The height cutoffs should be also compared with the tree and shrub data collected on the large and small plots to determine the presence or absence of vegetation at each layer.



Photos

Photos are a critical means of documenting site changes over time. A set of photos should be taken at plot center in each cardinal direction. Another photo from north of the plot center toward plot center should also be taken.

Use a compass to orient the placement of the photos. Place a label within the frame of each photo with the plot number, date, and direction. Ideally, this label can be placed in the lower third of the photo by clipping the label to vegetation or a chaining pin. Copies of pretreatment photos should be brought during repeat measurements to frame photos similarly.

For regular photo points that occur at other important views and sites within the project, it can be helpful to use or place a landmark within the photo. This allows the monitoring team to snap a quick and consistent shot when they happen to notice interesting changes, no compass required. The photographer's location can be marked with one type of benchmark such as a piece of rebar. Then at some distance away, a nail with survey whiskers attached can become the photo landmark. Whenever a photo is taken, the photographer positions the whiskers at the center of the bottom of the viewfinder.

Overstory canopy cover

Overstory canopy cover is an expression of the portion of the ground within a plot that would be shaded by tree foliage if a light source were directly overhead. It is described as a percentage of the total ground area of the plot. The total cannot exceed 100 percent. The timing of measurement for overstory canopy



Structural Vegetation Type	Height	Characteristics	Example
Type I	> 40 feet	Mature and mid-aged stands with well-developed understory at all heights	
Type II	> 40 feet	Mature overstory trees with little or no understory foliage	
Type III	20-40 feet	Intermediate-sized trees with dense understory vegetation	
Type IV	0-15 feet	Intermediate-sized trees with little understory vegetation	
Type V	0-15 feet	Younger stands with dense, shrubby growth	
Type VI	0-5 feet	Very young, low, and/or sparse stands, either herbaceous or woody	
Openings/Bare	---	Less than 25% vegetated	

TABLE 3. HINK AND OHMART (1984) STRUCTURAL CLASS DESCRIPTIONS

cover is constrained by season in riparian areas. Overstory cover must be measured during the peak growing season because most of the overstory consists of deciduous species. Measurements recorded too early in the spring may underestimate cover because trees will not have leafed out completely. Similarly, measurements recorded too late in fall will underestimate cover if leaf fall has already begun.

Instruments used for assessing canopy cover include spherical densiometers, sight tubes, and photos using a fisheye lens and specialized software. Spherical densiometers are the most reliable and cost effective method for measuring canopy cover. Densiometers use a curved mirror to detect tree canopy. Cover is typically determined using four observations made at or near the plot center.

Measurements Recorded Within the Small Plot

- Understory Canopy and Surface
- Seedling and sapling species and density
- Surface fuels

The small plot is laid out by dividing the plot into four sections using two measuring tapes. For a 1/300-acre small plot, as shown in Figure 6, the tapes are placed facing north and east, perpendicular to each other, with the mark at 6.8 feet along each tape placed at small plot center. The tapes subdivide the small plot into quarter sections to improve cover estimation. The end of each tape is anchored by a chaining pin which together with anchors or pinflags at 13.6 feet serve to delineate the small plot boundary. Alternatively, the tape extending from large plot center can serve as the east/west line and a second

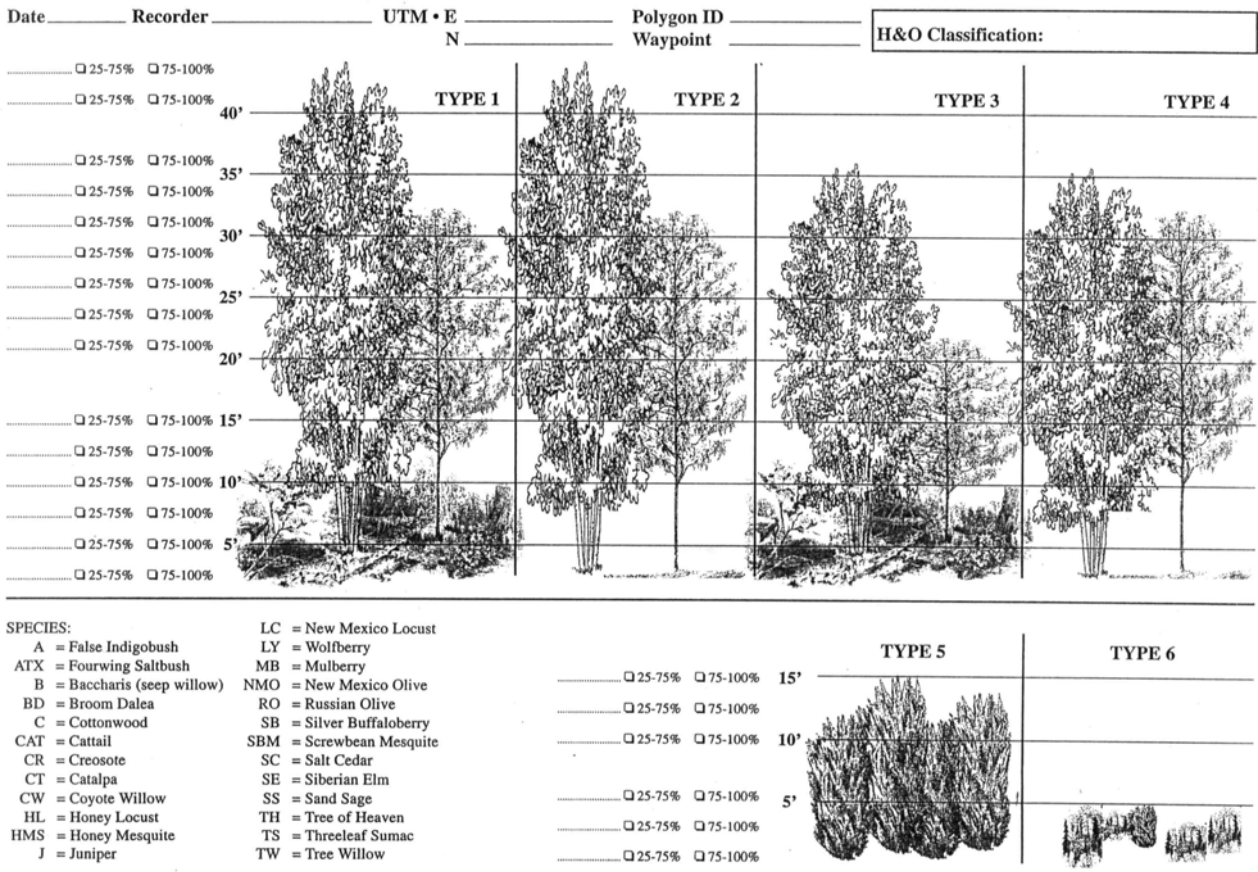

FIGURE 5. STRUCTURAL CLASS WORKSHEET (SWCA 2006) BASED ON HINK AND OHMART (1984)

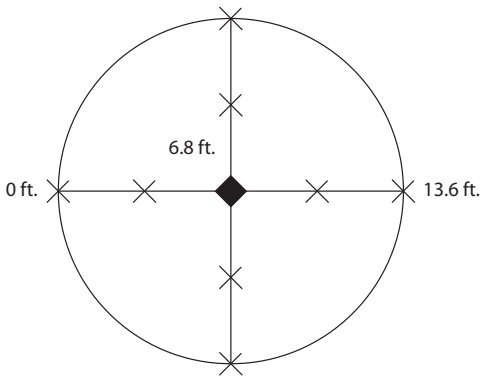

FIGURE 6. SMALL PLOT LAYOUT (1/300 ACRE)

tape can be placed north/south at the 15 foot mark to designate the small plot area.

Understory Canopy and Surface Cover

As with overstory canopy cover, a good way to think about understory cover is as the amount of ground that would be shaded by the vegetation if a light source were directly overhead. Visible small openings between and within the plant crowns are not tallied separately (foliar cover). Visually estimating the percent cover within a plot is considered a semiquantitative technique (Bonham 1989), and estimation is generally more accurate on small plots as opposed to large plots. Cover is estimated for two layer categories: woody understory and ground cover. Cover estimates for the woody understory categories include all species present. Size class trends and

species composition within the woody understory are captured by estimating cover by species. Since individual plants must be countable to estimate density (Bonham 1989), shrubs will not be counted. In some cases seedling and sapling tallies may be useful.

Since mature trees (>5 inches DBH or DRC) will be measured on the large plot, any cover provided by these trees can be ignored within the small plot.

All vegetation whose canopy overhangs the plot area is included even if rooted outside the plot boundary. No single category of cover can exceed 100 percent; however, the total can exceed 100 percent since upper layers of some species or cover types may over-top lower layers of different species or cover types. Although additional species or indicators of interest to the project can be added, the cover measurements should include those listed in Table 4. In addition to the criteria shown in Table 4, the shrub layer is considered less than 15 feet tall to correspond with the layer parameters used to assign the Community Structure Class (see Table 3 on page 20).

Cover is expressed as a percent and is recorded as such. In some cases, it may be more desirable to estimate coverage within one of six coverage classes, as suggested by Daubenmire (1959) (Table 5).

Seedling and sapling species and density

In projects where detailed information on resprouts is required, such as in comparing the relative effectiveness of different herbicides, stems should be counted by species within the small plot to achieve estimates of stem density rather percent cover. Individual projects may track individual species, life forms, or other additional subcategories. Guidelines and protocols for monitor

Woody understory layer	Seedlings	Height: <4.5 feet
	Saplings	Height: >4.5 feet DBH/DRC: <5 inches
	Shrubs	Any colonial species with no stem greater than 5 inches DRC or as defined by the project
Ground cover layer	Graminoids	Grasses
	Forbs	Herbaceous plants (not grass)
	Litter	Deciduous leaves, needles, branches, slash, mulch, or other loose materials on the ground, other than gravel.
	Bare soil	Mineral soil visible
	Rock	Large rocks or rock mass
	Gravel	Small, loose stones on the ground
	Water or wet soil	As defined by the project

TABLE 4. PERCENT COVER MEASUREMENT CATEGORIES ON THE SMALL PLOT

understory vegetation at the species level are beyond the scope of this guide.

Density and species composition of seedlings and saplings are important components of riparian wildlife habitat and contribute to understanding potential fire risk. Tracking the density and growth patterns of resprouts also helps to assess treatment effectiveness and determine proper maintenance schedules. Seedlings and saplings are defined by the height and diameter criteria shown in Table 4 and are tallied by species. To tally the seedlings and saplings, start at the west edge of the northeast quadrant of the subplot and count seedlings and saplings in each category, progressing in a clockwise direction across the subplot. Tallies for each plot and category will be averaged and densities determined as part of the data summary process, described later in this guide.

Chipped or Masticated Surface Fuels

Surface fuels are normally measured as part of the larger plot using the Brown's Transect method, detailed on page 28. Although this time-tested method accurately characterizes many types of forest slash and litter, it is not well suited for measuring mechanically treated fuel beds because the fuel loading calculations are based on round fuel particles while masticated or chipped fuels tend to be shredded into irregular shapes and sizes. To measure fuels in these circumstances, depth mea-

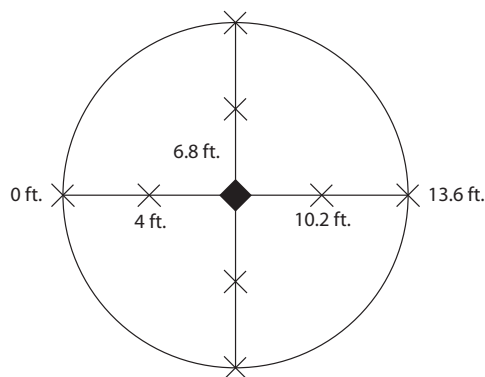

FIGURE 8. MULCH DEPTH MEASUREMENT LOCATIONS (X) WITHIN SMALL PLOT

Coverage Class	Range of Coverage, %	Midpoint of Coverage Class, %
1	0-5	2.5
2	5-25	15
3	25-50	37.5
4	50-75	62.5
5	75-95	85
6	95-100	97.5

TABLE 5. DAUBENMIRE COVERAGE CLASSES

(DAUBENMIRE 1959)

surements can be taken within the small plot and converted to loading estimates based on the depth to mass relationship.

Mulch depth is measured four times along each transect that delineates the small plot. Using the two short, perpendicular tapes as a guide, measure the woody litter depth at each of the eight locations using a ruler (Figure 8). The placement of the measurement is not crucial. Simply measure depth at each edge of the small plot, at 4 feet, and 10 feet. Each measurement is made as follows:

- Scrape away only as much material as needed to get a good view of the ruler.
- Record each measurement.
- Back in the office, the average depth and the fuel loading based on specific gravity will be calculated and summarized.

Measurements Recorded Within the Large Plot

- Tree data
- Tree status
- Tree diameter
- Tree height
- Crown base height
- Surface Fuels

Tree Data

Tree species, height, diameter and crown base height are recorded for each tree. Any stem with a diameter at the root collar (DRC) or diameter at breast height (DBH) larger than five inches is treated as a tree. Tree diameter and height are collected for both live and dead trees. Data are recorded in a field book or on a form such as that shown in Figure 9. In some species such as tamarisk, the life-form (shrub or tree) may be dependent on the site and site history. Individual projects should assign life-form categories and measurement rules based on species composition and project objectives. When performing tree measurements, start facing north and progress in a clockwise direction across the plot. Measurements for each plot will be averaged and densities determined as part of the data summary process, described later in this guide. Diameter and height may be broken into project defined classes for the data summary; however, actual, observed values should be measured and recorded in the field.

Tree Status

Tree status is a determination of whether a tree is alive or dead. Standing dead trees are also known as snags. For some projects, live trees may be further characterized as healthy, unhealthy, sick, or some other category. The specific descriptions of each of these health categories will be determined by the sponsoring agency or the multiparty monitoring team.

Tree Data Form

Observer: Wanfall Date: 11/11/11 Administrative Unit: SF-10

Recorder: Zebrowski Time: 0940 Project Unit:

Plot: 7

Tag #	Tree Status	Species	Tree Count	DRC # Stem	DBH/ DRC	Height	Height to crown	Crown Ratio	Crown Class		Comments
1	l	sc	1	1	1.3	12	9				
	l			2	0.8	12	9				
	l			3	1.2	13	9				
	d			4	1.35	21	/				
	d			5	1.44	22	/				
2	d	ro	1	6	3.7	15	/				
3	l	ro	1	1	5.2	21	2				
4	l	sc	1	1	6.1	17	2				
5	d	sc	1	1	11.3	18	4				
6	l	sc	1	1	2.7	7	/				
7	l	sc	1	1	10.4	14	4				
	d			2	8.5	15	3				
	l			3	5.2	12	/				
	d			4	8.8	10	4				
8	l	unk	1	1	4.2	12	/				choke cherry?
9	l	sc	1	1	2	12	3				
10	l	sc	1	1	17.6	18	3				
				2	7.4	16	3				
next page											

Descriptions/Codes		
Tree Status	Crown Class	Tree Species:
L = Live	OP = Open	sc = salt cedar
D = Dead	DO = Dominant	ro = Russian olive
	CO = Codominant	unk = unknown
	IN = Intermediate	
	OV = Overstopped	

Notes:
sc = Siberian elm

FIGURE 9. DBH AND DRC MEASUREMENT

Tree Data Form

Sheet 1 of 2

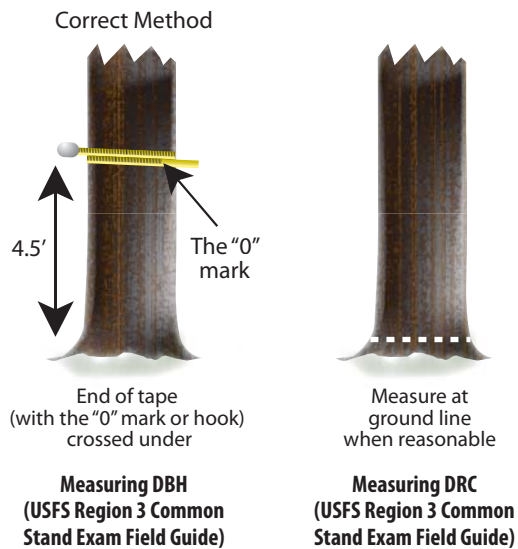

FIGURE 10. DBH AND DRC MEASUREMENT

Tree Diameter

DBH is the outside bark diameter at 4.5 feet above the forest floor on the uphill side of the tree. DRC is the diameter measured at the root collar or at the natural ground line, whichever is higher (USFS 2010). Any tree species that commonly has multiple stems should be measured at the root collar. Figure 10 illustrates the concept of DBH and DRC measurement. DBH measurements are typically made using a diameter tape (d-tape), while DRC is measured using calipers. More detailed examples of DBH and DRC measurement are shown in Appendix 4. Table 6 provides a list of some multi-stemmed species that may be encountered in riparian projects and that are typically measured at the root collar. However, the list is not comprehensive. In addition, the method of diameter measurement – DBH or DRC -- should remain consistent for a species throughout the project.

Measuring and Calculating DRC

Diameter measurements of all qualifying stems (≥ 1.5 inches diameter and at least one foot in length) are measured and the observed values recorded. For a single-stemmed tree, DRC is equal to the single diameter measured. For multi-stemmed DRC-measured trees with at least one stem ≥ 5.0 inches at the root collar, DRC is computed as the square root of the sum of the squared stem diameters. This computation is performed in the office, during data summarization.

$$DRC = \sqrt{\sum_1^n (\text{stem diameter})^2}$$

Example: Tree #1 has three qualifying stems; 5.9, 2.4, and 1.5:

$$DRC = \sqrt{(5.9)^2 + (2.4)^2 + (1.5)^2} = 6.5$$

Tree diameters will be averaged by species for each plot and for the entire project area as part of the data summary.

Tree Height

Although it is preferable to measure the height of each tree, in some cases a few trees can be measured to train the observer's eye. The height of the remaining trees can then be estimated based on the sampled trees. Three general methods are available for accurately measuring tree height.

Scientific Name	Common Name	Plant Code
<i>Acer negundo</i>	boxelder	ACNE2
<i>Juniperus monosperma</i>	oneseed juniper	JUMO
<i>Juniperus scopulorum</i>	Rocky Mountain juniper	JUSC2
<i>Prosopis spp</i>	mesquite	PROSO
<i>Robinia neomexicana</i>	New Mexico locust	RONE
<i>Salix spp.</i>	willow	SALIX
<i>Tamarix spp.</i>	salt cedar	TAMAR2
<i>Elaeagnus angustifolia L.</i>	Russian olive	ELAN

TABLE 6. SPECIES COMMONLY MEASURED AT ROOT COLLAR (USFS 2004)

Clinometers measure tree height using the principle of similar triangles. By knowing the length of a side of a triangle and one angle, other dimensions can be calculated. The length of one side of the triangle is determined by the distance the person stands from the bole of the tree. One type of clinometer using a topographic, or t, scale requires that this distance be one chain

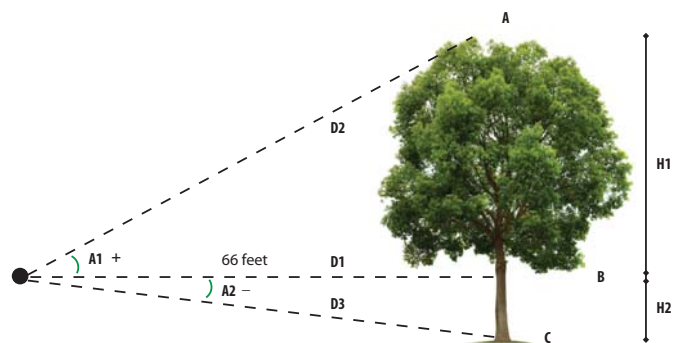

FIGURE 11. CLINOMETER USE (ADAPTED FROM USFS, 2010B)

or 66 feet and the value for height is read directly as the bottom reading subtracted from the top reading. Other clinometers use a percent scale, with the height calculated as the bottom reading subtracted from the top reading, that difference expressed as a decimal, then multiplied by the observer's horizontal distance from the object (Figure 11). Both types of clinometers often look the same, so it is important to check which type of clinometer you are using. Furthermore, many clinometers include both a t scale and a percent scale, so it is important to pay close attention to the configuration of the clinometers to avoid using the incorrect scale.

Another method for measuring height is using a stadia or surveyor's rod. This method is limited to trees below the height of the rod. Care should be taken to ensure that the rod is held perpendicular to the ground (Figure 12).

When available, the most efficient method for measuring tree height is the use of a laser hypsometer. However, because of their relatively high cost, laser hypsometers are generally not available to most multiparty monitoring teams.

Tree heights will be averaged by species for each plot and across the project area as part of the data summary.



Photo: Colin Lee

FIGURE 12. MEASURING HEIGHT OF RUSSIAN OLIVE WITH SURVEYOR'S ROD

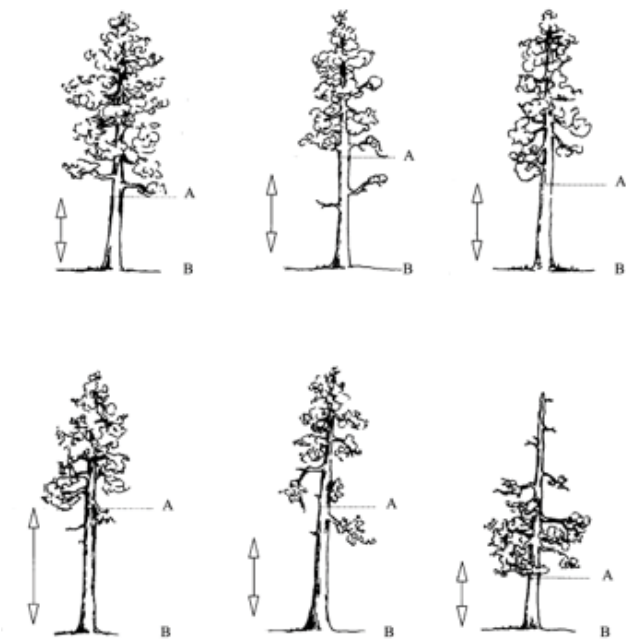

FIGURE 13. MEASURING HEIGHT TO CROWN (FROM USFS 2010B)

Height to Crown (Crown Base Height)

Crown base height (CBH) is the distance between the ground and the lowest live branches in the live crown of an individual tree (Moote et al. 2009). The base of the live crown is defined as the lowest branch whorl with live branched in at least two quad-

rants, exclusive of epicormic branches and whorls not continuous with the main crown (Figure 13). Epicormic branches are buds or shoots of the main trunk or stem and whose origins cannot be traced to the tree's pith.

To measure crown base height, measure the height from the base of the tree on the uphill side (B) to the base (A) of the live crown, excluding any individual branches (Figure 13). When recording this measurement, be sure to note in the comments section any trees that stand out as not being typical or representative of the majority of the trees in the stand.

Other Tree Measurements

Other observations and measurements may be required, based on project requirements and the determination of the multiparty monitoring team. These include crown ratio (the percentage of the tree's height that includes live foliage) and crown class (a description of the tree's position relative to competing vegetation). In some cases, various tree health or disease indicators, such as insect damage or mistletoe, may be requested. Procedures for performing these observations and determinations are beyond the scope of this work. The Common Stand Exam Field Guide Region 3 (USFS 201b) is a good reference on these and other common tree measurements.

Natural Surface Fuels

Surface fuels are commonly measured using the planar intercept technique, often referred to as the Brown's transect (Brown 1974).

The following descriptions of the technique and datasheets are adapted from CFRP Handbook 4: Monitoring Ecological Effects (Savage et al. 2006) and the CFRP Short Guide (Moote et



Surface fuels like logs and branches can burn hot and carry fires into tree crowns. In riparian areas, non-native trees can produce large amounts of dead and down wood that increase the risk of crown fire. The reduction of surface fuels is an important restoration goal. However, it is wise to leave some dead and down wood on the ground to foster wildlife and understory growth.

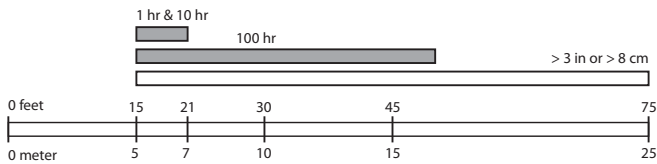

al. 2009). For complete detailed explanations, three good background documents are: Fuel Load Sampling Methods from the FIREMON web page; the DWM Field Manual for 2004 from the USDA-Forest Service Northern Research Station web page; and Brown et al. (1982).

Data collection method

Surface fuels are measured on two short transects that originate at plot center or at a point located near, but not within the large plot, as determined by the multiparty monitoring team. The first surface fuels transect needs to be placed at due north from the plot center. The second transect runs south east from the transect origin, along an azimuth of 135 degrees. The surface fuels transect should be 60 feet long, starting 15 feet from transect origin. In some very dense riparian areas, the transect length may have to be shortened to 35 feet. Note the slope of the fuels transects—both will be needed for the analysis. Also make note of the transect’s azimuth, so you can repeat measurements in the future.

The method requires counting all pieces of dead wood that cross the transect in four size categories and measuring the diameter of the largest size class. Count only dead wood not attached to a live tree. Do not count rotten wood, cones, needles, or forbs. Count the same piece twice if it crosses the transect twice. The four categories of size to be counted are:

1. less than 1/4 inch in diameter (mainly small twigs);
2. larger than 1/4 inch but smaller than 1 inch in diameter;
3. larger than 1 inch but smaller than 3 inches in diameter; and
4. three inches and larger in diameter.

You must also measure and record the actual diameter of the wood pieces in the largest size category (3 inches and larger). Measure the diameter at the point where it crosses the fuel transect.

The fuels measurement is much easier if you use a small piece of cardboard or wood with little slots cut out for 1/4 inch and 1 inch. The piece of cardboard can be 3 inches in length. This way, the cardboard can be simply held up to a piece of dead wood to determine its size quickly. Bring several of these into the field, as they tend to wear out.

Count all pieces of wood in the smallest two size categories on the first six feet of the fuels transect. The smallest category will include all pieces of wood that fit into the 1/4-inch slot. The second category will include pieces of wood that are too large for the 1/4-inch slot, but fit in the 1-inch slot. Record the number of pieces of wood for each of these size categories.

Count all pieces of wood in the third category of size, larger than 1 inch but smaller than 3 inches, in the first 35 feet of the fuels transect. You will be going over the first 6 feet of the fuels transect again. These pieces of wood will be too large to fit in the 1-inch slot but will be smaller than the width of the 3-inch cardboard. Record the number of pieces of wood of this size category.

Lastly, look for pieces of wood larger than 3 inches in diameter lying across the entire 60 feet of fuels transect. There is no upper limit to the size of wood in this category. For pieces of wood larger than 3 inches, you also need to measure and record diameter. Measure the pieces of wood with a d-tape. There is a place on the data sheet to tally the number of pieces of wood of this size as well as the size of each piece.

These observations are used to compute fuel loading in tons per acre and then summarized for each plot and for the entire project area, as described in the data summary section.

Measurements Recorded Across Project Area

- Depth to Groundwater
- Soil Salinity and Texture



Depth to Groundwater

Monitoring groundwater levels yields general information essential to the success of any riparian restoration project (Pollock et al. 2005). Understanding the depth to groundwater, fluctuations in groundwater levels, and the depth to saturation can greatly improve restoration success because hydrology is a primary factor driving species composition in riparian areas. Where floodplain terraces are disconnected from the river channel and flooding is limited, the depth to groundwater will be a critical parameter driving the potential for restoration and appropriate revegetation. In general, areas where the groundwater is more than 8-10 feet below the surface should be treated as upland sites in terms of species

selection and site potential (Dreesen 2010). As a rule of thumb, ground water levels within eight feet of the surface indicate good riparian restoration potential in the arid Southwest. Most native cottonwood and willow species require a groundwater depth of 4-5 feet (Dreesen 2010). Seasonal fluctuations and periods of inundation may require a selection of species that are tolerant of periodic flooding (Dreesen 2010; Pollock et al. 2005).

Shallow groundwater wells are typically used to monitor water table elevations and provide representative water chemistry samples from the saturated zone levels (Thibault 2008). Monitoring wells are often referred to as piezometers but true piezometers are different in that they have a very short intake and are designed to measure hydraulic head from pressure head and elevation head (Thibault 2008). Instructions for installing shallow groundwater monitoring wells in sandy, alluvial soils are provided in Appendix 2. Installation in cobble or bedrock may require specialized expertise and/or equipment. The soils map and topography will help to identify these locations. Site size and variability along with funding constraints should dictate the number of wells installed.

For projects where significant replanting will take place, groundwater elevation should be measured monthly at each well location for a full year prior to planting. Seasonal activities such as ditch irrigation can dramatically alter the water table elevation, thereby affecting the choice of planting technique and timing. Measuring the depth to groundwater in each well can be done manually or using an automated logger depending on the depth and the level of information required to address project objectives. For a shallow groundwater system, a cloth measuring tape or piece of wood trim can be inserted into well and the level of water/wetness recorded. The most commonly used device for general measurement is the water level meter or “beeper,” consisting of a probe on the end of a long tape. When the probe contacts water, it produces a sound and the depth reading on the tape is recorded. For continuous measurement of water levels, automated water level loggers can be placed in each well. The loggers minimize staff time but are more costly in terms of the units themselves and the additional hardware and



Materials Needed

- 1/8-cup (30 mL) measuring cup
- 120-mL plastic containers with lids
- EC pocket meter
- squirt bottle
- calibration solution (0.01 M KCl)
- distilled water

software required for transferring data.

Soil Salinity and Texture

Soil properties should be measured at the outset of a project whenever revegetation will take place. Determining soil texture in year one will help to determine whether soil parameters should be measured annually thereafter. In coarse-textured, well-draining soils, salinity may be lowered through leaching over time. It may be helpful to monitor this process. In heavy clay soils, high salinity can be persistent and salt-tolerant plant materials should be chosen for the site (Table 8).

Soil properties may be measured directly in the field or soil samples may be collected and sent to a laboratory for analysis. Laboratory testing includes a broad range of soil characteristics but field measurements are relatively easy and can be accomplished by students. The Soil, Water, and Agricultural Testing Laboratory at New Mexico State

Collecting a Soil Sample



1. Using a trowel, scrape away any vegetation or litter to expose mineral soil.
2. Use a trowel or auger to collect a sample from about 0-6" deep.
 - a. If only a surface sample is desired, a small metal cup

can be pounded into the soil surface. A trowel placed underneath contains the sample as it is turned upright. Similar metal cups are available from restaurant equipment suppliers. If a snapshot of soil moisture is desired, the samples can be weighed in the cups to obtain a wet weight. Then, the samples can be placed in an oven and dried at the lowest possible temperature for several hours. Soil moisture can be computed from weight/dry weight.

3. Place all samples from each soil type or vegetation community into a labeled resealable storage bag.
4. Remove any roots, leaves, stones, etc.
5. Mix the sample well.

Materials needed:

- Trowel
- Auger
- Permanent marker
- Metal cup
- Resealable storage bags

Soil Property	Suitability			
	Good	Fair	Marginal to Poor	Very Poor
pH	6.0 - 8.4	5.5 - 6.0 or 8.4 - 8.8	5.0 - 5.5 or 8.8 - 9.0	< 5.0 or < 9.0
EC (dS/m or mmhos/cm)	0 - 4 Growth of salt-sensitive species may be limited	4 - 8 Growth of many plants is limited	8 - 16 Only salt-tolerant plants grow satisfactorily	< 16 Only a few, very salt-tolerant plants grow satisfactorily
Texture	sandy loam, silty loam, sandy clay loam	clay loam, silty clay loam, sandy clay, loamy sand	clay, silty clay, silt, sand	parent material
SAR	< 6	6 - 10	10 - 15	> 15
% Organic	> 1	0.5 - 1	< 0.5	0
Nitrogen (Nitrate NO ₃)	> 200 ppm (> 0.2%)	100 - 200 ppm (0.1 - 0.2%)	50 - 100 ppm (0.05 - 0.1%)	0 - 50 ppm (0 - 0.05%)
Phosphorus	> 100 ppm (> 0.1%)	60 - 100 ppm (0.05 - 0.1%)	30 - 60 ppm (0.02 - 0.05%)	0 - 30 ppm (0 - 0.02%)

Table 8.

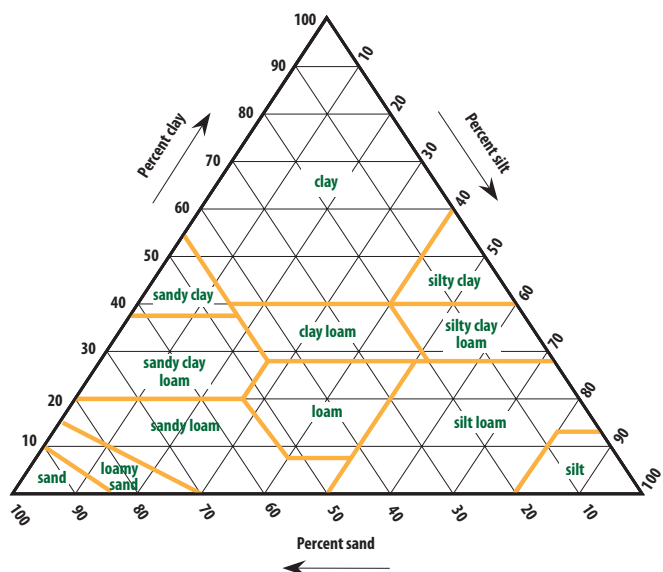

University (swatlab.nmsu.edu/) performs a range of soil analyses.

Soil samples for either field or lab analysis should be collected in at least three places within each vegetation community or soil type (based on NRCS soil map) and combined into one bulk sample following the instructions on page 29.

Soil Salinity:

Soil salinity can be measured in the field following the method below adapted from NRCS Soil Quality Tests Kit Guide (NRCS 2001). Soil salinity is analyzed by testing the electrical conductivity (EC) of a soil sample. Because EC is measured on a fluid, the test is performed by mixing a soil sample with water.

Steps:

1. Use the scoop to remove a 1/8 cup subsample from the large, bagged soil sample.
2. Add 1/8-cup (30 mL) of distilled water to the container with the subsample. The resulting soil/water mixture equates to a 1:1 soil to water ratio on a volume basis.
3. Put the lid on the container and shake vigorously about 25 times.
4. Measure and Record EC.
5. Be sure to calibrate meter according to manufacturer guidelines.
6. Open the container and insert the EC pocket meter into the

Materials Needed

- water
- squirt bottle
- texture by feel instruction sheet
- distilled water

soil-water mixture. Take the reading while the soil particles are still suspended in solution. To keep the soil particles from settling, stir gently with the EC pocket meter. Do not immerse the meter above the immersion level. Allow the reading to stabilize (stays the same for about 10 seconds).

7. Record the EC reading in decisiemens per meter (dS/m). Different meters may require calculations to reach dS/m. The calculations may be found in the device manual.
8. Turn the meter off. Thoroughly rinse meter with distilled water and replace cap.

What the numbers mean:

Levels above 3 are too saline for many species. Levels above 8 are considered very harsh and suitable for a very small number of species that are considered halophytes or salt lovers (Dreesen 2010).

Soil Texture

The most straight forward method for field testing soil texture is to “ribbon test” using the “Soil Texture by Feel Flow Chart” (Thien 1979) (Figure 16), to assign a texture class. When a higher level of precision is desired, soil sieves (Figure 15) may be used to determine particle sizes and construct soil texture classes.



FIGURE 15. SOIL SIEVES

Soil Texture by Feel Flow Chart

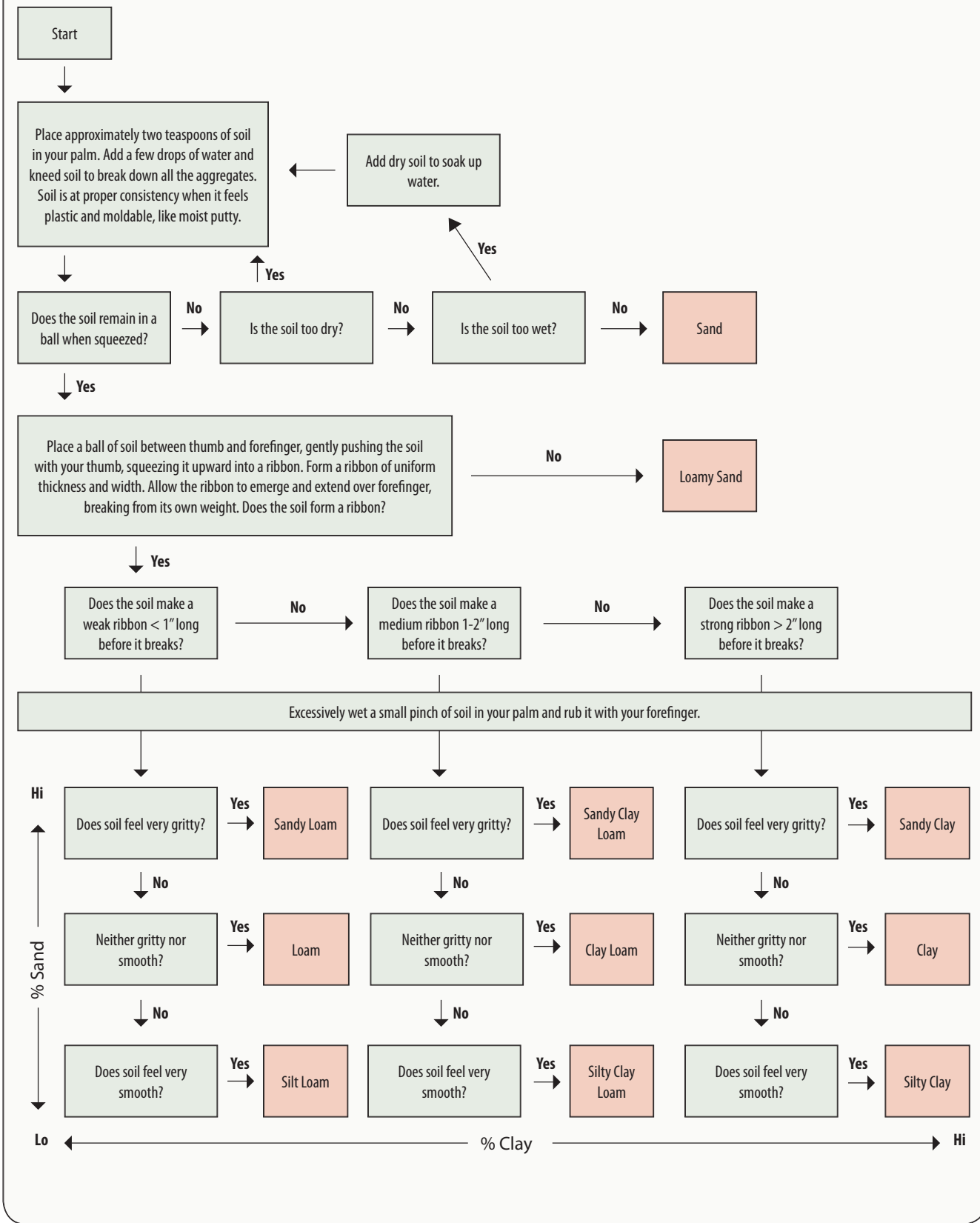

FIGURE 16. SOIL TEXTURE BY FEEL (THIEN 1979)

Summarizing the data

Once the field data are collected, it must be summarized to determine plot and project area statistics for each ecological indicator. It may also be appropriate to report indicator statistics for each of the project area's strata. These summaries and statistics can be performed using a variety of tools and methods, from pencil and paper

through sophisticated ecological data analysis tools. This section describes the statistics that need to be generated and suggest some ways to present that information. Depth to groundwater, soil salinity, and soil texture are site specific determinations and are not summarized for the entire project area. Ultimately, the land manager will provide direction on how these data are to be presented.

Community Structure

Because community structure is a qualitative determination, it cannot be described with detailed statistics. A simple table showing the community structure of each plot can be built. A summary paragraph can also be written that mentions the majority and minority community structures and discusses any trends and patterns for the entire project area.

Canopy and Ground cover

Create a table displaying the percent cover in each category for each plot, as recorded in the field notes. Then calculate the mean for each category for the entire project area. The means for the project area can be reported in a format such as this:

	Seedlings	Saplings	Shrubs	Gramanoids	Forbs	Litter	Bare Soil	Rock	Gravel	Water or wet soil
Plot #										
Plot #										
Average for project area										

Recall that the total cover may exceed 100% due to overlapping canopies.

If Daubenmire coverage class is used, create a similar table showing the classes for each plot. In this case, though, and average is not determined. Instead, the general trends can be described in the body of the report.

Seedling and Sapling Density

A summary table for seedlings and saplings can be created directly from the data recorded in the field. Seedling data are reported in each height class and saplings in each diameter class, as shown below.

Macro Plot Name	Seedlings - Height			Saplings - Diameter			
	<2.5'	2.5-4.49'	TOTAL	<1"	1-3"	3-4.49"	Total
Total							
Density (Stems per acre)							

Tree Data

Field recording of individual tree data should be transferred to a simple table for each plot, in a format similar to that shown below:

Plot Name	Tag No	Species Symbol	Status	DBH/DRC	Basal Area	Height	Height to Crown
Total trees:			Average:				

A simple table reporting the averages across the project area should also be created.

Trees Per Acre		Basal Area (sq. ft/acre)		Live Crown Base Height		Height (Ft)		Snags Per Acre	
Mean of Plots	Total	Mean of Plots	Total	Mean of Plots	Lowest Plot Mean	Mean of Plots	Mean of Stand	Mean of Plots	Total

Then summarizing data for the entire stand, report an average of the plot averages, where appropriate, and the overall stand averages. Note that the average of the plot averages is not the same as the stand average. When developing averages for the entire stand or project area, the raw totals of all observations at all plots should be used. For example, a total of 500 trees may have been observed in a stand with 15 1/10 acre plots. The total area sample would be 1.5 acres (15 x 0.10 = 1.5). This stand will then have a density of 333.3 trees per acre (500/1.5 = 333.3). The same rule applies when reporting height and diameter averages for the entire stand, average the actual measurements taken across the entire project area.

For some projects, plot and stand averages may be further broken down by height classes and diameter classes. The definition of these classes will be determined by the sponsoring agency or the multiparty monitoring team.

The following sections explain how each of tree data item is computed.

Live and Dead Tree Density and Size

Density is the number of individual plants per unit area and expresses a sense of how close plants are to one another. Density is typically reported as trees per acre, by species, and in total. Tree diameters and heights are summarized by species, and in total, for each plot. The plot summary should include the total number of trees and the average height and diameter for the trees. The total trees per acre should be computed by species, and in total. This is done by dividing the number of trees on the plot by the plot size. For example, a 1/10 acre plot with 75 trees would have a tree density of 750 trees per acre (75/0.10 = 750). Summarize live trees and dead trees on separate tables.

Tree heights are simply averaged for each plot by species and in total. For multi-stemmed trees, the height of each stem is included in the overall plot and stand average.

For single stemmed trees, the recorded DBH or DRC is used for the plot and stand summary. Recall that for a single-stemmed tree measured at root collar, the tree's DRC is equal to the single diameter measured. For multi-stemmed DRC-measured trees, DRC is computed as the square root of the sum of the squared stem diameters. This computation is performed as follows:

$$DRC = n \sqrt{\sum_1^n (\text{stem diameter})^2}$$

Example: Tree #1 has three qualifying stems; 5.9, 2.4, and 1.5

$$DRC = \sqrt{(5.9)^2 + (2.4)^2 + (1.5)^2} = 6.5$$

(USFS Region 3 Common Stand Exam Field Guide, USFS 2010b)

Most projects will require that basal area also be reported. Basal area (which is typically reported in square feet) is the cross sectional area of a tree based at DBH or DRC. It is determined using the formula for the area of a circle, πr^2 , and the recorded DRC or DBH. For example, a tree with a DRC of 12-inches will have a basal area of 0.79 square feet ($3.1416 * (12/2)^2 = 113.1$ square inches = 0.79 square feet). However, generally the constant .005454 is used to convert a diameter in inches to a basal area in square-feet (.005454 is the quantity π divided by 4(144), where the 4 converts tree diameter² to radius² and 144 converts the diameter² in inches² to a corresponding measurement in feet²). For example, the basal area of a tree with a DBH of 14 inches would be: $14^2 * .005454$ or 1.07 square feet. Basal area is normally totaled, and not averaged for the plot and for the stand or project area.

Remember to summarize live trees and dead trees separately.

Height to Crown

The height to crown is summarized for each plot. When averaging the height to crown for a plot, exclude any outliers where a single tree might be oddly shaped. Enter the height to crown information into each plots summary table and determine a plot average. For the stand or project area summary, report the lowest average height.

Surface fuels

Brown's Transect data analysis method

The data analysis method for surface fuels is provided below. It is adapted from the CFRP Short Guide by Moote et al. (2009). The result of your calculation will be one value—average tons of surface fuels per acre for your site. In addition to the method described below, on-line programs such as FFI exist, which calculate fuel loading of down woody debris. Table 9 is an example of a worksheet that can be used to calculate surface fuels.

Fuel Class (hours)	Size class (inches)	(1) Constant	(2) N	(3) Diameter ² *	(4) Specific gravity**	(5) Secant	(6) Slope factor	(7) Total transect length	(8) Total tons per acre
1	0-0.25	11.64		0.015	.52	1.13			I:
10	0.25-1	11.64		0.206	.52	1.13			II:
100	1-3	11.64		2.661	.52	1.13			III:
1000	3+	11.64		Square the diameter of each piece; add these together	.52	1.00			IV:
								Total: I + II + III + IV =	V:

* Woodall and Monleon 2009, ** FIA Database

To find tons per acre for each size class, multiply (1) x (2) x (3) x (4) x (5) x (6) and divide the resulting number by (7). See text to find values for these columns.

To find total tons per acre, add I + II + III + IV to get total V. Fill in columns (1) – (8) using the following methods:

Filling out the table:

(1) Constant: This is 11.64 for all size classes.

(2) N: For sizes less than 3 inches, this is the number of pieces encountered in each size class. For sizes over 3 inches, this value is 1.

(3) Diameter²: Each size class less than 3 inches, has a value based on the dominant forest type.

For sizes over 3 inches, you do not need to use the table to determine diameter². Instead, square the diameter for each piece encountered and add these squares together. Enter this “sum of squares” into the space in column (3).

For example, if you encountered three pieces of debris, measuring 3.8”, 6.1”, and 12.0”, you would compute the following:

$$(3.8 \times 3.8) + (6.1 \times 6.1) + (12.0 \times 12.0) = 14.44 + 37.21 + 144.0 = 195.65$$

Enter 195.65 into the space in column (3) of the table.

(4) Specific gravity: Based on the forest type. This is the same for all size classes.

(5) Secant: This is a number which corrects for the fact that pieces of debris do not lie at perfectly perpendicular angles to the transect line. The number you use will depend on the size.

For pieces less than 3” the secant is 1.13

For pieces 3” and larger the secant is 1.00.

(6) Slope factor: This is a number which corrects for the average slope of the transects. Use Table 11 to determine what value to enter into column (6):

(7) Total transect length: This is the total length of transect line, calculated for each size class. To derive this value, multiply the number of transects by the length of each transect. This value will be different for different size classes, since the length of transect varies for each size class. For example, if you had two transects of six feet long for measuring the 0-0.25” size class, your total transect length would be $6 \times 2 = 12$. In these same two transects, if each transect was 60 feet long for the 3” + size class, your total transect length for that row would be $2 \times 60 = 120$.

(8) Calculating fuel load: For each size class, multiply the values in columns: (1) x (2) x (3) x (4) x (5) x (6).

Divide the product of these six columns by the value in column (7). This will give you tons per acre for each size class. To calculate total fuel load, simply add the values in column (8) for each size class: I + II + III + IV. The sum of these values is the total fuel load of your sampled area, measured in tons per acre.

Slope (%)	Correction factor
0	1.00
10	1.00
20	1.02
30	1.04
40	1.08
50	1.12
60	1.17
70	1.22
80	1.28
90	1.35
100	1.41
110	1.49

Table 11 Slope Correction Table

Mulch Depth Analysis

Instead of measuring small fuel classes along the transect, depth measurements can be taken within the small plot and converted to loading estimates based on the depth:mass relationship.

The most common method for relating mulch depth to mass is using bulk density, or the weight per unit volume. Bulk density values reflect the weight of the wood and the amount of air or compaction. Bulk density can be highly variable depending on the species treated and the equipment used. As a result, Knapp et al. (2008) found the depth method to be reliable within a site, but it did not perform well

when comparing data between sites. Currently, no values for mulch fuel bed bulk density have been reported in the literature for riparian projects. The bulk density suggested (7.5 lbs ft⁻³) is based on a series of weight measurements of tamarisk and Russian olive woody litter following mechanical treatments in New Mexico (Bonfantine unpublished; Bulsterbaum unpublished). This value has been compared with a number of other relevant values such as those for western hardwoods in Woodall and Monleon (2009) and determined to provide more reasonable loading estimates.

The instructions for calculating loading are as follows:

Calculate the average depth (D) for all eight field measurements.

Calculate the loading (tons acre⁻¹) using the following formula:

$$\text{Loading (tons acre}^{-1}\text{)} = 13.6 \times D$$

An explanation for derived formula may be helpful. First, the average depth measurement in inches is assumed to cover an acre and converted to volume:

$$V = \frac{D \times a}{b}$$

where:

V= volume of mulch (ft³ acre⁻¹)

D= average depth (inches)

a= 43,560 ft² acre⁻¹

b= 12 in ft⁻¹

Then volume is converted to loading using bulk density:

$$L = \frac{V \times BD}{c}$$

where:

L= loading (tons acre⁻¹)

V= volume of mulch (ft³ acre⁻¹)

BD= bulk density (lbs ft⁻³) = 7.5

c= 2000 lb ton⁻¹

Although the most scientifically defensible data may come from higher numbers of mulch depth measurements (e.g. Battaglia et al. 2010), the focus here is to balance statistical significance with efficient implementation. Because so many aspects of calculating riparian fuel loading based on mulch depth are still rough approximations, the number of depth measurements was scaled back from the 12 recommended in the BBIRD protocol to 8. As research expands in this emerging area, estimates should improve and these methods will likely evolve over time.

Data interpretation

The objective is to reduce surface fuels to safe levels. Too much surface fuel can burn hot enough to carry fire into the canopy of the trees; however, some surface fuels are valuable for wildlife habitat and for providing wetter sites where tree seedlings and understory plants can germinate. Restoration should not aim to remove every scrap of surface fuels, or to create a very “clean” forest floor.

The results of the surface fuels measurement may vary considerably depending on treatments and forest type. For example, some sites have little surface fuels before treatments, but more when debris remains on the ground after trees have been cut down and partially removed, masticated, or mulched. The post-treatment measurement may indicate that there is a dangerous amount of fuel on the ground that requires attention. On the other hand, removing large amounts of surface fuels are often a specific target of riparian restoration and the prescription will include a requirement to remove slash and other woody debris. A comparison of before and after treatment surface fuels values should then show a dramatic reduction in tons of wood per acre. Note in your report when the post-treatment data were collected: Were they collected before final slash removal? Were they collected before a planned prescribed burn? The surface fuel monitoring values should be compared to prescription targets for your site and forest type.

Wrapping up the Monitoring Project

Once the monitoring is complete, you will need to write a report describing the work accomplished. This report must, at a minimum, include:

- CFRP Project number and description.
- Responsible organization (grantee).
- Project location, including name of the administrative unit (e.g. Forest Service National Forest and District names). Be sure to include a map.
- Names, roles, and affiliations of all persons involved with the monitoring.
- When the monitoring was accomplished.
- Data summaries. Include a map showing the monitoring location and a table showing the geographic coordinates of each plot.
- Conclusions, observations, and recommendations.

The report should be well organized. It should include a table of contents and the pages should be numbered. If possible, provide the hardcopy version in a tabbed binder. A softcopy version, ideally in PDF format, bookmarked by chapter, should accompany the

hardcopy report.

In addition to the report, provide the CFRP coordinator and land manager a copy of all field sheets and electronic copies of data analysis spreadsheets, maps, plot and other documentary photographs, and geographic information systems data files. All electronic files should use a simple, but descriptive naming convention. Retain the original field sheets and softcopy files in a safe location. Make sure they are clearly marked with the project name and date.

The final report and accompanying data are the legacies of the monitoring project. This information will likely be put to immediate use in project implementation by land managers. Pre-treatment monitoring data will inform the development of treatment prescriptions. Post-treatment monitoring data will be used to judge whether the treatments were implemented as prescribed. These data also serve as an important historical record of the project area. They may be used to evaluate ecological change over time and to help evaluate the effectiveness of the treatments.

The report and data are the only tangible records of the work accomplished. Regardless of how the data are used, it should be presented in a professional manner and be a document that the monitoring team is proud of.

Cited References

- Avery T, Burkhardt H. Forest measurements. 5th ed. Boston: McGraw-Hill; 2002.
- Battaglia MA, Rocca ME, Rhoades CC, Ryan MG. Measuring mulch fuelbed loads. Unpublished handout; 2010.
- Bonham C. Measurements for terrestrial vegetation. New York: John Wiley & Sons; 1989.
- Brown JK. Handbook for inventorying downed woody material. Ogden (UT): USDA Forest Service, Intermountain Forest and Range Experiment Station; 1974. Report No.: GTR-INT-16.
- Brown JK, Oberheu RD, Johnston CM. Handbook for inventorying surface fuels and biomass in the interior west. Ogden (UT): USDA Forest Service, Intermountain Forest and Range Experiment Station; 1982. Report No.: INT-129.
- Daubenmire R. A canopy-coverage method of vegetational analysis. *Northwest Science*. 1959;33:43-64.
- Dick-Peddie WA. New Mexico vegetation, past, present, and future. Albuquerque (NM): University of New Mexico Press; 1993.
- Dreesen D. USDA Plant materials center agronomist; 2010.
- Egan A. Sampling intensities and sampling errors associated with pre-and post-treatment forest restoration monitoring: the Ute Valley inventory. Las Vegas (NM): New Mexico Forest and Watershed Restoration Institute; 2011. White Paper.
- Egan A, Estrada-Bustillo V. Socioeconomic indicators for restoration projects: a delphi study. Las Vegas (NM): New Mexico Forest and Watershed Restoration Institute; 2011. Technical Report.
- Dwire KA, Kauffman JB. Fire and riparian ecosystems in landscapes of the western U.S. *Forest Ecology and Management*. 2003;178:61-74.
- Finch DL, Jemison R, Chung-MacCoubrey A, Galloway JM, Hawksworth DL, Means MD, Stropski CL, Owens K. Annual report for middle Rio Grande fuels reduction study, 2003. [place unknown]: USDA Forest Service, Rocky Mountain Research Station; 2003.
- Gregory SV, Swanson FJ, McKee WA, Cummins KW. An ecosystem perspective of riparian zones: focus on links between land and water. *Bioscience*. 1991;41:540-551.
- Hauser AS. *Distichlis spicata*. In: Fire Effects Information System [Internet]. [place unknown]: USDA Forest Service, Rocky Mountain Research Station, Fire Sciences Laboratory (Producer); 2006 [cited 2011 June 8]. Available from: <http://www.fs.fed.us/database/feis>.
- Herrick JE, Van Zee JW, Havstad KM, Burkett LM, Whitford WG. Monitoring manual for grassland, shrubland and savanna ecosystems. Las Cruces (NM): USDA-ARS Jornada Experimental Range; 2005.
- Hink VC, Ohmart RD. (Center for Environmental Studies, Arizona State University, Tempe, AZ). Middle Rio Grande biological survey. Final report. [Albuquerque (NM)]: U.S. Army Corps of Engineers; 1984. Contract No.: DACW47-81-C-0015.
- Howard JL. *Atriplex canescens*. In: Fire Effects Information System [Internet]. [place unknown]: USDA Forest Service, Rocky Mountain Research Station, Fire Sciences Laboratory (Producer); 2003 [cited 2011 June 8]. Available from: <http://www.fs.fed.us/database/feis>.
- Husch B, Beers TW, Kershaw JA. Forest mensuration. 4th ed. New York: John Wiley & Sons; 2002.
- Johnson RR, Haight LT, Simpson JM. Endangered species vs. endangered habitats: a concept. In Importance, preservation and management of riparian habitat. [place unknown]: USDA Forest Service; 1977. Report No.: RM-43. p.68-79.
- Knapp EE, Busse MD, Varner JM, Skinner CN. Masticated fuel beds: custom fuel models, fire behavior, and fire effects. Final Report to Joint Fire Science Program. Redding (CA): USDA Forest Service. Pacific Southwest Research Station; 2008. Project No.:05-2-2-20.
- Martin TE, Hochachka CJ, Conway CJ, Jenkins JW. BBIRD field protocol. Missoula (MT): Montana Cooperative Wildlife Research Unit, University of Montana; 1996.
- Mian I, Herrera J, Vigil T, Duran A, Moquino G. Traditional ecological knowledge: informing bosque restoration at Tesuque Pueblo. [place unknown]: The Southwest Community Forestry Research Center and Forest Guild; 2004.
- Moote A, Savage M, Abrams J, Derr T, Krasilovsky E, Schumann M. Multiparty monitoring and assessment of collaborative forest restoration projects - short guide for grant recipients. Flagstaff (AZ): Ecological Restoration Institute and Las Vegas (NM): New Mexico Forest and Watershed Restoration Institute; 2010.
- Natural Resources Conservation Service (NRCS). Soil quality test kit guide. [place unknown]: USDA, Agricultural Research Service, Natural Resources Conservation Service, Soil Quality Institute; 2001.
- New Mexico Department of Game and Fish (NMDGF). New Mexican wildlife of concern. Biota Information System of New Mexico (BISON-M). Santa Fe (NM): New Mexico Department of Game and Fish. Conservation Services Division; 2000.
- Pollock MM, Beechie TJ, Chan SS, Bigley R. Monitoring restoration of riparian forests. In: Roni P, ed. Monitoring stream and watershed restoration. Bethesda (MD): American Fisheries Society; 2005. p.67-96.

Savage M, Schumann TM, Abrams J. CFRP handbook 4: monitoring ecological effects. [place unknown]: USDA Forest Service; 2006.

Savage M, Derr T, Evans A, Krasilovsky E, Smith K, Carey H. Short guide for developing collaborative forest restoration project restoration prescriptions. Las Vegas (NM): New Mexico Forest and Watershed Restoration Institute; 2008. Working Paper 1.

Sher A, Lair K, DePrenger-Levin M, Dohrenwend K. Best management practices for revegetation after tamarisk removal in the upper Colorado River basin. Denver (CO): Denver Botanic Gardens; 2010.

Smith RL. Elements of ecology. New York: Harper Collins; 1992.

Society for Ecological Restoration International. Science & Policy Working Group. The SER international primer on ecological restoration. Tucson (AZ): Society for Ecological Restoration International; 2004.

Stone KR, Pilliod DS, Dwire KA, Rhoades CC, Wollrab SP, Young MK. Fuel reduction management practices in riparian areas of the western USA. *Environmental Management*. 2010;46:91-100.

SWCA Environmental Consultants. Hink and Ohmart structural class datasheet. [place unknown]: [publisher unknown]; 2006.

Thibault J. (University of New Mexico. Dept. of Biology). Instructions for installing shallow groundwater wells. [Unpublished]; 2008.

Thien SJ. A flow diagram for determining general soil texture by feel analysis. *Journal of Agronomic Education*. 1979;8:54-55.

Triepke J. e-mail correspondence, Subject: CFRP Riparian Monitoring Handbook, March 22, 2011.

Uchytel RJ. *Panicum virgatum*. In: Fire Effects Information System [Internet]. [place unknown]: USDA Forest Service, Rocky Mountain Research Station, Fire Sciences Laboratory (Producer); 1993 [cited 2011 Jun 8]. Available from: <http://www.fs.fed.us/database/feis>.

USDA. Forest Service. Fuel load (FL) sampling methods. [Internet]. Final draft. In: FIREMON (Fire Effects Monitoring and Inventory System) Sampling Methods web page; [date unknown; cited 2011 Jun 8] [0.6 MB]. Available from: http://frames.nbii.gov/portal/server.pt/community/firemon/286/sampling_methods/490.

USDA. Forest Service. DWM field manual for 2004 [Internet]. Newtown Square (PA): USDA-Forest Service. Northern Research Station; 2004 [cited 2011 Nov 22]. [2.4 MB]. Available from: <http://www.nrs.fs.fed.us/ifa/topics/dwm/data-collection/>.

USDA. Forest Service. Forest Service manual 2000 - National forest resource management, Chapter 2020 - Ecological restoration and resilience. Washington DC: USDA, Forest Service; 2010.

USDA. Forest Service. Common stand exam field guide region 3. [place unknown]: USDA, Forest Service; 2010.

U.S. Fish and Wildlife Service. National list of vascular plant species that occur in wetlands. [place unknown]: U.S. Fish & Wildlife Service; 1988. Biological Report 88 (26.9).

Walters DT, Doran JW, Aulakh MS. Effects of soil aeration, legume residue, and soil texture on transformations of macro and micronutrients in soils. *Soil Science*. 1992;153:2.

Woodall CW, Monleon VJ. Estimating the quadratic mean diameter of fine woody debris for forest type groups of the United States. In: McRoberts RE, Reams GA, Van Deusen PC, McWilliams WH, editors. Proceedings of the eighth annual forest inventory and analysis symposium; 2006 Oct 16-19; Monterey, CA. Washington DC: USDA, Forest Service; 2009. Report No.: Gen. Tech. Report WO-79. p.185-190.

Appendices

Appendix 1. Additional monitoring resources

Appendix 2. Instructions for installing shallow groundwater wells

Appendix 3. Sample field data collection forms

Appendix 4. Tree height and diameter measurements

Appendix 1. Additional monitoring information resources

Topic Area	Description	URL
Revegetation	"Best Management Practices for Revegetation after Tamarisk Removal in the Upper Colorado River Basin" is a comprehensive, detailed handbook filled with information and color photos. Available for purchase (\$15 plus shipping).	www.botanicgardens.org/content/conservation-and-research-publications
Revegetation	Los Lunas Plant Material Center guidance	www.nm.nrcs.usda.gov/programs/pmc.html
Salt Cedar and Riparian Restoration	The Tamarisk Coalition is a non-profit that provides education and technical assistance for the restoration of riparian lands.	www.tamariskcoalition.org
Salt Cedar Removal, Biomass and Revegetation	A good comparison of equipment and techniques compiled by the Tamarisk Coalition.	www.tamariskcoalition.org/PDF/Appendix%20H%20-%20Assessment%20of%20Alternative%20Technologies.pdf
Plants	Information on plant selection and planting techniques from the New Mexico NRCS office.	www.nm.nrcs.usda.gov/plants.html
Plants	Detailed information on plants including photos, species codes, range maps, and wetland indicator status.	http://plants.usda.gov/java/
Wetland plants	Lists of riparian plant species in NM according to their wetland indicator status. Includes photos of some species.	http://aces.nmsu.edu/riparian/
Soils	NRCS site allows user to download soil surveys as shapefiles. User can also generate custom reports.	http://soildatamart.nrcs.usda.gov/
Soils	NRCS site allows user to create soil survey for a defined area. Produces a report that includes descriptions of soil map units.	http://websoilsurvey.nrcs.usda.gov/app/HomePage.htm
Monitoring Stream and Watershed Restoration -Rapid Assessment	A guide developed by USFS, NRCS, and BLM that uses a wide range of factors to assess the functional quality of riparian systems	ftp://ftp.blm.gov/pub/nstc/techrefs/Final%20TR%201737-15.pdf (either and FTP client or Windows® browser must be used to access file.)
Monitoring Stream and Watershed Restoration -Rapid Assessment	A scientifically defensible rapid assessment technique developed specifically for the unique situations encountered in NM. Available soon through the NM Natural Heritage Program at UNM.	http://nhnm.unm.edu/
Monitoring Stream and Watershed Restoration	A comprehensive text compiled by the American Fisheries Society. Available through the American Fisheries Society bookstore. (\$65)	http://afsbooks.org/x55047xm
Grazing Assessment	USFS/BLM Technical Bulletin - Monitoring Stream Channels and Riparian Vegetation-Multiple Indicators	www.blm.gov/id/st/en/info/publications/technical_bulletins/tb_07-01.html
Monitoring Grassland, Shrubland, and Savanna Ecosystems	Excellent quantitative monitoring protocols from the USDA Jornada Experimental Range. Two volumes cover a wide range of techniques.	http://usda-ars.nmsu.edu/monit_assess/monmanual_main.php

Appendix 2. Instructions for installing shallow groundwater wells

(Thibault, J. 2008)

Bosque PVC Ground Water Monitoring Wells JRT August 08 (rev)

I. Introduction

Shallow ground water (GW) wells are used in the bosque to monitor water table (WT) elevations and to provide representative water chemistry samples from the saturated zone. Networks of wells can be used to determine shallow subsurface flow paths and spatial and temporal biogeochemical characteristics of GW.

The wells are composed of two-inch internal diameter PVC pipe with a solid upper casing and an intake that intersects the WT. The intake is the screened segment of the well through which GW flows. In the shallow, mostly unconfined aquifers typical of the bosque research sites, the water level in the well is a good indicator of the depth to the water table (DWT).

Piezometers differ from monitoring wells in that they are constructed with a very short intake and are designed to measure hydraulic head from pressure head and elevation head. The water level in a piezometer generally does not give the direct position of the WT. Nested piezometers set at various depths are used to measure GW gradients and to construct flow nets. However, they are less suited for biogeochemical sampling than monitoring wells because the short intake restricts yield and represents a limited region of the saturated zone.

If possible, the well intake should be of sufficient length to encompass the range of expected WT elevations (Fig.1). This may not be possible during flooding and high flows or during very dry periods with low flows.

The optional time to install wells is during baseflow when low WT elevations facilitate hole boring in the bosque. Baseflow conditions depend of course on weather conditions, and vary in time and space along the Middle Rio Grande. We have observed low flows during:

1. April, when irrigation begins but prior to peak snowmelt runoff.
2. Late June, post snowmelt peak and prior to summer monsoon season.
3. Late September/early October, post monsoon season but before the end of irrigation season.

II. Supplies, Tools and Equipment (2003 prices)

A. Supplies (available at Rodgers & Co., Inc., Isleta SE, ABQ—UNM POs accepted)

- PVC pipe – 2" ID Sch 40, screened (0.01" or 10-slot,

\$30.30/10') for intake and solid (\$5.60/10') for casing. Amount depends on DWT, flooding vs. non-flooding site, etc. Pipes come in various lengths, are sold by the foot, and come with male and female threaded ends. Solid pipe ends might also be sold unthreaded, some with built-in coupling. Unthreaded solid pipes w/coupled joints are less likely to break.

- 2" PVC drive points, male and female threaded (\$7.50 ea.) depending on your screened pipe ends. Slip-type points that are inserted into non-threaded screen pipe are also handy for cut lengths of screened PVC, but may not be available at Rodgers. 1/well.
- 2" slip couplers to join pipes as needed – depends on # of solid PVC ends w/built-in coupling, but slip couplers are handy for extending well lengths, etc. (\$1.30 ea.).
- 2" PVC well caps – slip type (\$1.02 ea.). 1/well. Locking types available, \$15-20 each.
- PVC primer and cement for some joint connections, e.g. slip points w/cut screen pipe.
- Bentonite – to seal annular space near surface, sold in 50# bags (\$6.03) as Hole- or Kwik-Plug. Go with 3/8" chips vs. pellets (costly) or powder. Enough for several wells.
- Silica sand – size 10-20 (\$6.23/50# bag), for the well filter pack. Plan on ~ 1 bag/well.

B. Tools/Equipment

- Soil auger w/3" (or 4") bucket and extensions, 2 adj. wrenches and strap wrench
- San Angelo rod w/spade end for breaking up roots, hard soils
- Steel rods for packing sand – 1-2, 1 long enough to reach near depth of well if possible
- Fence post driver that fits over PVC pipe
- Sledgehammers – 1 large (10-12 lb. head), one small (for packing rods, etc.)
- Sledgehammer blocks – ~15" L 4"x4" blocks w/partially bored hole that fits over the 2" PVC pipe. Note – fence post driver preferred over sledgehammer driving; see p. 4.
- Stepladder – to stand on if necessary when starting the well driving
- Pipecutter – for ≥ 2 " pipe
- 10m graduated 1/2" PVC pole for measuring depths in bore hole
- Water level indicator (beeper)
- Tape measure (w/metric highly preferable)
- Well bailer
- Duct tape, hacksaw, large screwdriver, WD-40, pipewrench, shovel
- Spray paint – cans of gray and brown spray paint to camouflage wells as needed
- Compass (or GPS unit), 100m tape, flagging loppers, and bow saw for siting wells

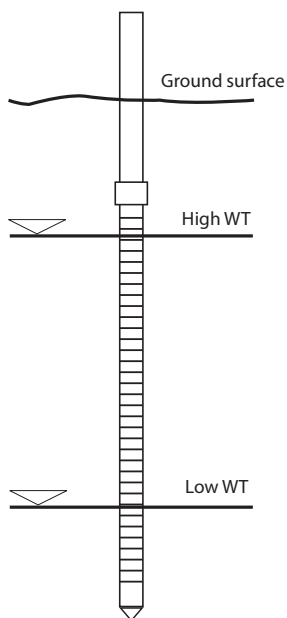

Figure 1: Intake screen should capture range in WT elevations if possible.

- Sediment sampling materials – Whirli-bags, dumping bin, trowel
- 5 gal bucket — for supplies and to stand on if necessary, e.g. starting the well driving

C. Misc. – head protection (hard hats/goggles, if using sledgehammer method), work gloves, site keys and permits, field book, pencil, calculator, black sharpie, rag or two, drinking water, bug spray

III. Well Installation

A. Bore Hole

- Auger down to WT, collecting sediment samples for texture analysis if desired. The seds should be sloppy-wet at the WT. If just damp you may have only reached the capillary fringe – keep digging.
- At the WT, the hole will collapse and boring deeper will be limited. Use the auger/rod to try to work (loosen) the seds at the WT and advance the hole as best you can (Fig. 2). This will facilitate driving in the well. Estimate DWT using the PVC rod or beeper.

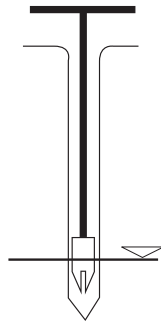

Figure 2: Work the seds with the auger to advance the hole.

B. Assemble the Well

- Determine the intake length based on the DWT. Try to extend the well ~ 100cm below the WT (more if WT is not near baseflow). The intake should end up ~ 25cm below ground. So, cut the screened PVC to the DWT plus 75cm (Fig. 3). It's best to use the pipecutter to ensure that connections are tight.
- Attach a drive point and a length of solid PVC for the casing to the intake screen. Use male/female or slip-type points and slip couplings as necessary. Use PVC primer and cement if necessary. The solid PVC should be long enough to cover the 25cm below ground depth and to fit the fence post driver (150cm is a good length).
- Now that the well is assembled, measure the effective screen length (Fig. 4), correcting for sections covered by couplings, etc. For example, a slip-type drive point inserted into a cut piece of screened PVC pipe will eliminate ~3.3cm of intake.
- Measure the well from the bottom, marking the casing at convenient intervals (e.g. 10cm, Fig 5). Also measure/mark a distance from the upper end of the intake to a point on the solid casing that will end up above ground, e.g. 150cm above the intake.

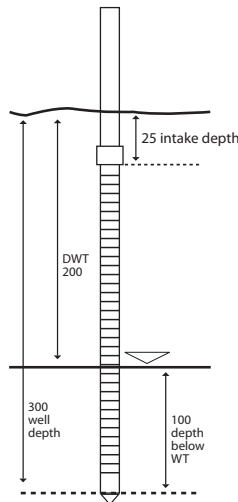

Figure 3: Determine the intake length. Ex: If DWT = 200 cm, cut 275 cm of screen length.

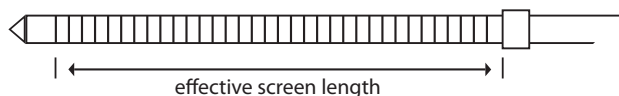

Figure 4: Measure effective screen length.

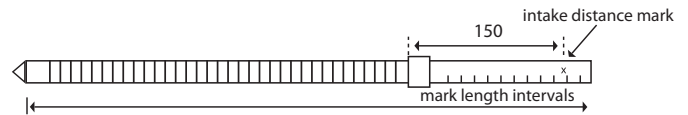

Figure 5: Mark length intervals and the intake measurement point on the casing before driving the well into the ground.

C. Insert the Well

- Drive the assembled well into the bored hole, working it in by hand as deep as possible.
- Cover the top of the well casing with a couple of strips of duct tape.
- Drive the well to the desired depth using the fence post driver. Less recommended is to place a wood block atop the casing and strike it with the sledgehammer (the block will need to be held in place by a crewmember – wear your hard hat, goggles and gloves). The sledgehammer can also be used to advance the fence post driver if it becomes too difficult to advance by hand – use a 2x4 scrap atop the post driver. With either method, don't use too much force or you risk shattering the well, particularly the intake. This is the main reason that it's best to install wells at baseflow, since the hole can be cored deeper and pounding the well is minimized. Driving the well may require standing on a stepladder.
- When the well is at the desired depth, determine the grade level where the casing and ground intersect and notch lightly with a saw. Now record the depth to intake: measure the distance from the intake distance mark you measured previously to the grade notch, and subtract this from the intake distance mark value. This is the depth to intake. Ideally, intake depth should be shallow, e.g. 25-50cm. If for some reason your intake mark is below grade (and you can still see it), add the distance to the grade notch.

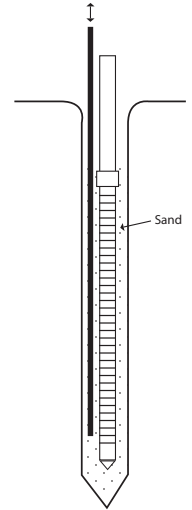

Figure 6: Tamp the filter pack.



Figure 7: Cut two notches at top of casing to locate beeper tape.

D. Pack the Well

- Partially fill the annular space around the well with the filter pack (silica sand). The filter pack enhances well yield and helps filter out fine materials that can accumulate in the well and clog the intake. Pour some sand, pack, and repeat as necessary (see next step).
- Tamp the sand with steel rods (Fig. 6) to eliminate gaps and make a tight packing. Wiggle the well to help move sand down the borehole. Fill and pack to ~ 10cm above the intake depth (measure w/rod or beeper). The well should be packed tight, difficult to spin by hand.

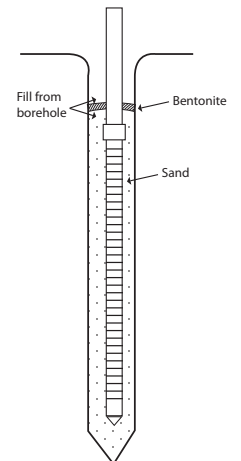

Figure 8: The annular space should include the sand filter pack and a bentonite seal sandwiched by native seds.

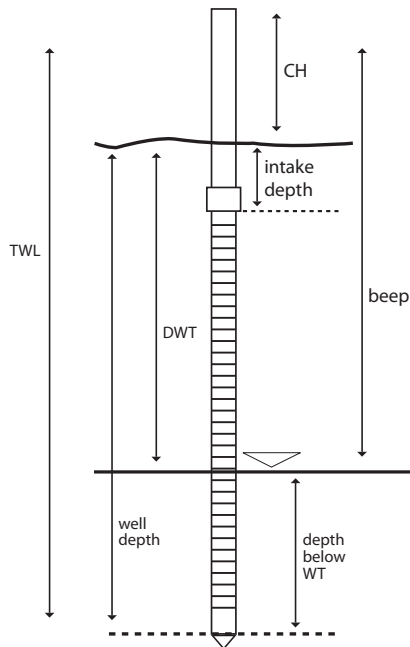

Figure 9: Well specs.

- Adjust the casing height to the desired length by cutting or extending with a coupler, e.g. $\leq 20\text{cm}$ in non-flooding sites, above potential flood level in flooding sites. A pipecutter makes a more level cut than a hacksaw and eliminates PVC shavings. Cut two notches in the casing $\sim \frac{1}{2}$ " apart with a hacksaw (Fig. 7). This area serves as the tape position when beeping the well. Make a final case height measurement from the sawed notch at grade level to the top of the well (between beep tape notches).
- Next, fill and pack with some of the extracted bosque sediments to within $\sim 10\text{cm}$ of the ground surface, then add a thin layer ($\sim 2\text{-}3\text{cm}$ thick) of bentonite around the casing (Fig. 7). Pour a couple of bailers' worth of water into the bentonite and allow to soak in. Fill the remainder of the hole with more of the extracted sediments and pack tightly around the base of the well with a short blunt object, e.g. the end of a hammer or wrench. Don't use the long rod, which could trash your bentonite layer.

E. Well Specs

- Label the well on the inside and outside of the casing.
- Beep the well. Calculate and record the well specs in your field book (see next page). It is helpful to sketch the well and fill in some of these data, similar to Fig. 9, next page.
- Effective screen length (measured before you installed well): _____
- Intake depth (determined before you packed the well): _____
- Casing height (CH): _____
- Total well length (TWL, measure from marked intervals on casing): _____
- Well depth (TWL - CH): _____
- Beep: _____
- DWT (beep - CH): _____

- Depth below WT (TWL - beep): _____
- Other info that might be useful to hydrogeology types:
 - Auger/borehole diam.: 10cm (4")
 - Intake diam.: 5cm (2")
 - Casing diam.: 5cm (2")
 - Screen slot size: 0.25mm (0.01")
 - Filter pack: 10-20 mesh silica sand
 - Surface seal: 3/8" bentonite chips

F. Work the Well

- Wells should be worked extensively after they are installed to clear fine materials and leach solvents if used (PVC cement).
- Elevate and drop the bailer several times to flush fines, etc. out of the well and filter pack annular space. Also, bail the well several times. The well water should become noticeably clearer. Cap the well LOOSELY, or use a locking cap if available.
- Wells should be worked regularly, especially prior to GW sampling.
- Make the well inconspicuous if it is in area susceptible to vandalism. Dry off the well casing and apply a coating of gray spray paint, then a few splotches of brown spray paint, or use camouflage spray paints, if available. Re-label the well over the paint with a black Sharpie, if necessary. Try to hide the well with branches, leaves, bark pieces, etc.

Appendix 3. Sample Data Collection Sheets

Plot Description - Riparian Projects

Observer: _____

Administrative Unit: _____

Recorder: _____

Project Unit: _____

Latitude (dd.ddddd): _____

Plot: _____

Longitude (dd.ddddd): _____

Date (DD/MM/YYYY): _____

Elevation: _____

Time: _____

Macroplot Size (Circle Column)				
Size (Acres)	1/100	1/20	1/10	
Radius (Feet, Decimal Feet)	11.78	26.33	37.24	
Radius (Feet, Inches)	11'9"	26'4"	37'3"	

Slope: _____

Aspect (circle one): **N** **E** **S** **W**

Mag Declination: _____

Photo 1 Position: **C** **N 66'**

Photo 1 Azimuth: _____

Photo 1 Time: _____

Additional Photo Azimuths: _____

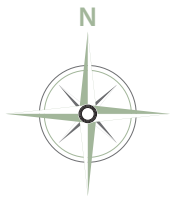

Cover (%)										
Tree Canopy	Seedlings/ Saplings	Shrubs < 5' / 5 - 15'		Graminoid	Forbs	Litter	Bare Soil	Rock	Gravel	Water or Wet Soil

Species	Small Plot – Tallies				
	Seedlings – Height		Saplings – DBH/DRC		
	< 2.5'	2.5 - 4.49'	< 1"	1 - 1.99"	2 - 2.99"

Comments:

Seedlings	Height: < 4.5 feet
Saplings	Height: > 4.5 feet DBH/DRC < 5 inches
Shrubs	Any colonial species with no stem greater than 5 inches DRC or as defined by the project
Graminoids	Grasses
Forbs	Herbaceous plants (not grass)
Litter	Deciduous leaves, needles, branches, slash, mulch, or other loose materials on the ground other than gravel.
Bare soil	Mineral soil visible
Rock	Large rocks or rock mass
Gravel	Small, loose stones on the ground
Water or wet soil	As defined by the project

Surface Fuels - Riparian Projects

Fine Woody Debris – Course Woody Debris

Observer: _____

Recorder: _____

Number of transects: _____

Administrative Unit: _____

Project Unit: _____

Macroplot: _____

Date (DD/MM/YYYY): _____

Time: _____

1- hour Transect Length - 6'	10-hour Transect Length - 6'	100-hour Transect Length - 35'	1000-hour Transect Length - 60'
------------------------------	------------------------------	--------------------------------	---------------------------------

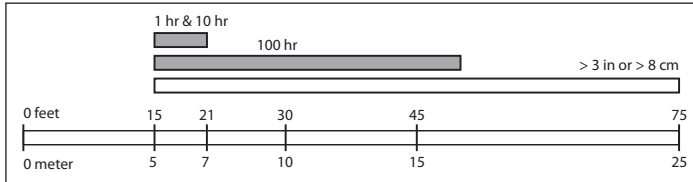

Class		Diameter (in)
FWD	1-hr	0 to .025
	10-hr	0.25 to 1.0
	100-hr	1.0 to 3.0
CWD	1000-hr and greater	3.0 and greater

Fine Woody Debris (1, 10, 100-hr fuels)	Transect	Azimuth	Slope	1- Hr Count	10-Hr Count	100-Hr Count	Comment
	1	0°/360°					
	2	135°					
	3	270°					

Course Woody Debris (1000-hr fuels)	Transect	Slope	Log No.	Log Diameter	Decay Class	Comment	

Precisions: Diameter: ± .05 in; decay class ± class; slope ± 5 percent

Decay Class Description

- 1 All bark is intact. All but the smallest twigs are present. Old needles probably still present. Hard when kicked.
- 2 Some bark is missing, as are many of the smaller branches. No old needles still on branches. Hard when kicked.
- 3 Most of bark is missing and most of the branches less than 1 in. in diameter also missing. Still hard when kicked.
- 4 Looks like a class 3 log, but the sapwood is rotten. Sounds hollow when kicked and you can probably remove the wood from the outside with your boot. Pronounced sagging if suspected for even moderate distances.
- 5 Entire log is in contact with the ground. Easy to kick apart, but most of the piece is above the general level of the adjacent ground. If the central axis of the piece lies in or below the duff layer, then it should not be included in the CWD sampling, as these pieces act more like duff than wood when burned.

Appendix 4. Tree Diameter and Height Measurements

Extracted from the Common Stand Exam Field Guide, Region 3, February 2010 (USFS 2010b)

Diameter at Breast Height (DBH)

DBH is outside bark diameter at 4.5 feet above the forest floor on the uphill side of the tree. To determine breast height, the forest floor includes the duff layer that may be present, but does not include unincorporated woody debris that may rise above the ground line. If a dead tree (snag) is missing bark, measure the DBH without the bark and record that measurement.

Forked tree: In order to qualify as a fork, the stem in question must be at least 1/3 the diameter of the main stem and must branch out from the main stem at an angle of 45 degrees or less. Forks originate at the point on the bole where the piths intersect. Forked trees are handled differently depending on whether the fork originates above or below 4.5 feet.

Trees forked below 4.5 feet are treated as distinctly separate trees. DBH is measured for each stem at 4.5 ft above the ground.

Trees forked at or above 4.5 feet count as one tree. If a fork occurs at or immediately above 4.5 ft, measure diameter below the fork just beneath any swelling that would inflate DBH.

Stump sprouts originate between ground level and 4.5 ft on the boles of trees that have died or been cut. Stump sprouts are handled the same as forked trees, with the exception that stump sprouts are not required to be 1/3 the diameter of the dead bole. Stump sprouts originating below 1.0 ft are measured at 4.5 ft from ground line. For multi-stemmed woodland species, treat all new sprouts as part of the same new tree.

Tree with irregularities at DBH: On trees with swellings, bumps, depressions, and branches at DBH, diameter will be measured immediately above the irregularity at the place it ceases to affect normal stem form. If this is not possible, because of the vertical extent of the irregularity, then adjust the DBH measurement to better reflect the diameter of a regular bole.

Tree on slope: Measure diameter at 4.5 ft from the ground along the bole on the uphill side of the tree.

Leaning tree: Measure diameter at 4.5 ft from the ground along the bole.

Turpentine tree: Usually in the Southwest. The tree is scarred to collect sap, mostly for naval products. A "turpentine face" is a result of this scarring. On trees with turpentine face extending above 4.5 ft, estimate the diameter at 10.0 ft above the ground and multiply by 1.1 to estimate DBH outside bark.

Independent trees that grow together: If two or more independent stems have grown together at or above the point of DBH, continue to treat them as separate trees.

Missing wood or bark: If 50% or more of the circumference of the bole is intact, reconstruct the diameter at DBH.

Diameter on stump: Use a logger's tape, cloth tape, or ruler to measure the longest and shortest axis across the top of the stump. Record the diameter as the average of the two measurements.

Proper Use of a Diameter Tape

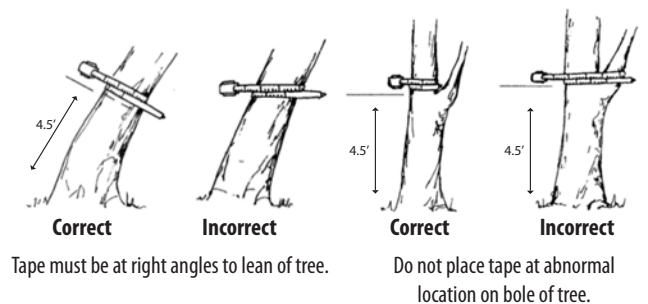
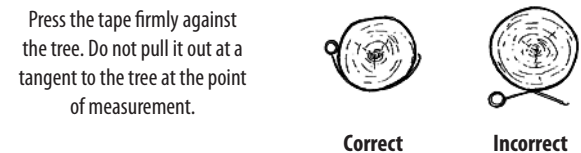
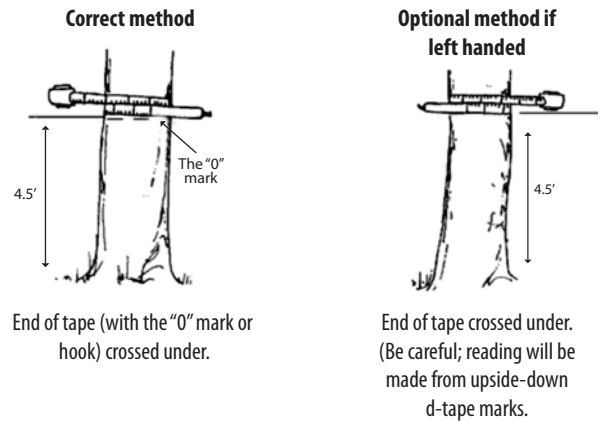

Point of Measurement for DBH

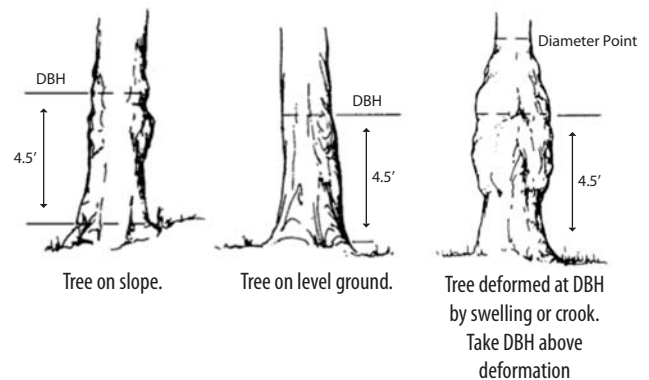

Point of Measurement for DBH (cont.)

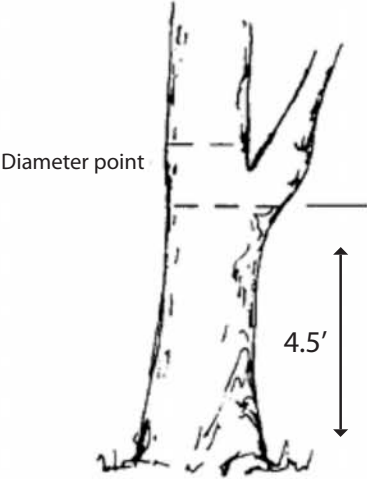

Tree with branch at 4.5 feet.

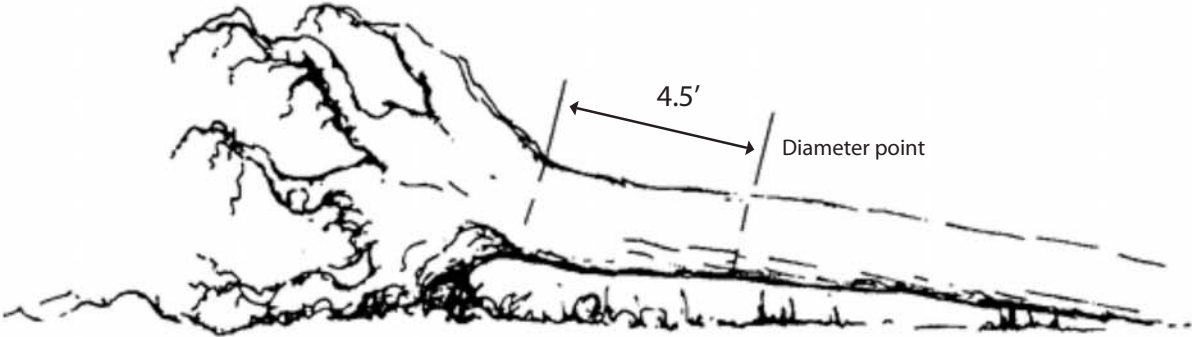

Windthrown tree.

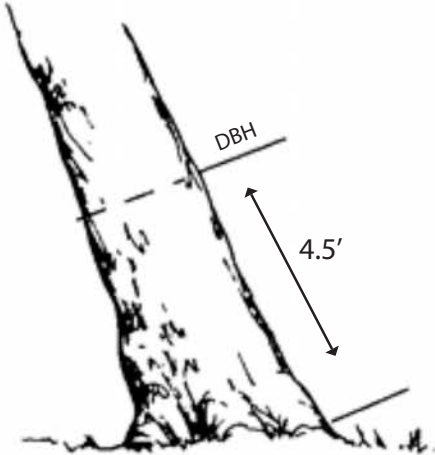

Leaning tree.

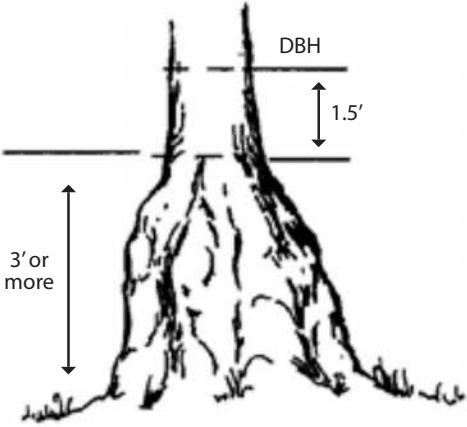

Bottleneck tree.

Point of Measurement for DBH (cont.)

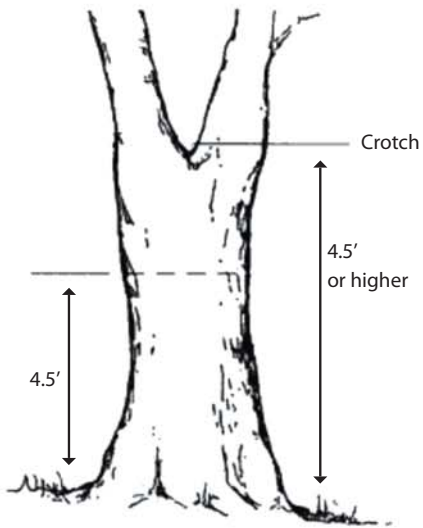
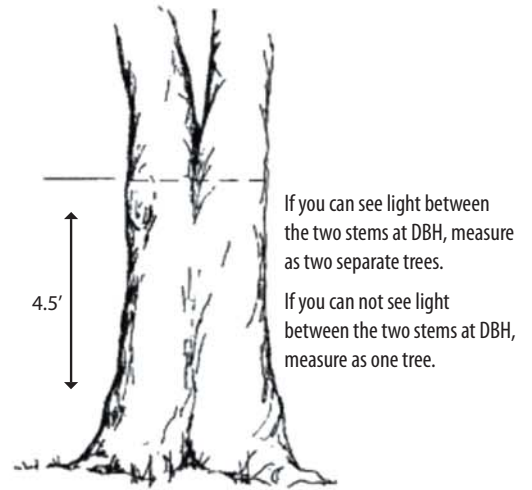
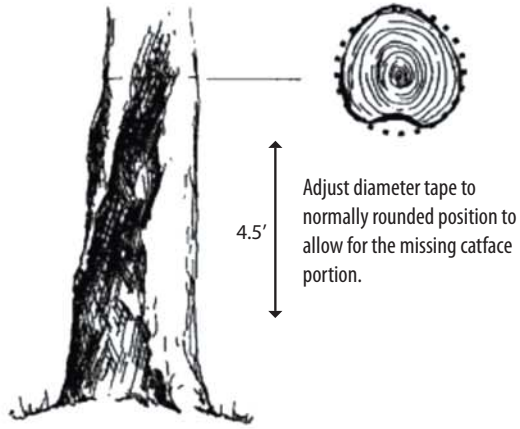

Tree forked at 4.5 feet or higher. Record as one tree and consider only the main fork. Take DBH below the swell of the fork.

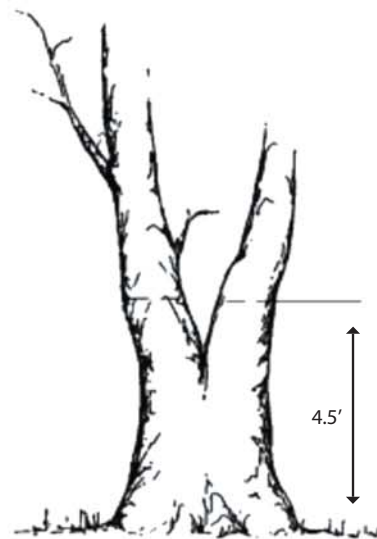

Tree forked below 4.5 feet. Record each fork that is "in" as a separate tree. Measure diameter at 4.5 feet.

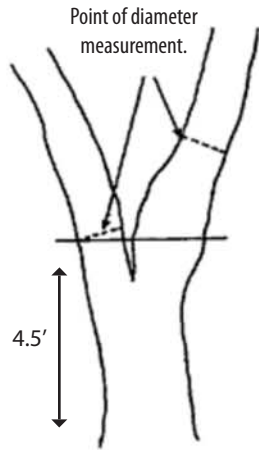

Measuring abnormal diameters on forked trees.

Diameter on abnormal fork.

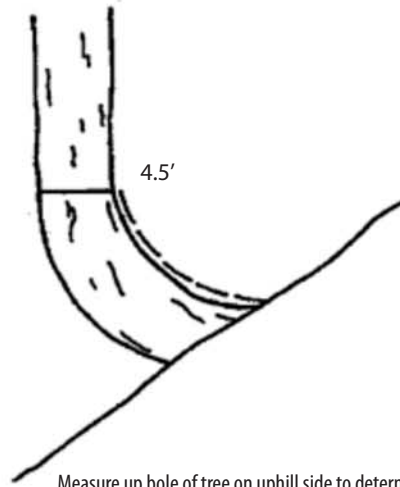

Measure up bole of tree on uphill side to determine height where DBH should be taken.

Diameter on pistol butt tree.

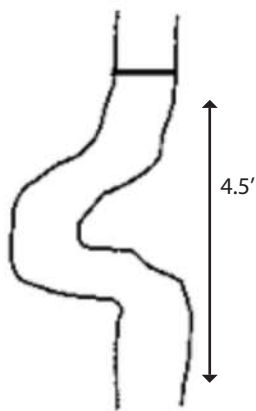

DBH measurement for a pistol butt shaped tree.

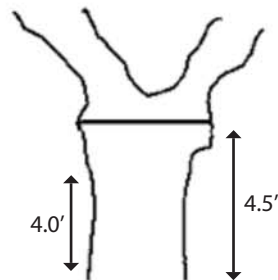

Three forked at DBH. Unable to get a DBH tape through crotch. Take DBH below the swell of the fork.

Diameter at Root Collar (DRC)

Diameter at Root Collar (DRC) is the diameter measured at the root collar or at the natural ground line, whichever is higher, outside the bark. Measure tree stems only, not branches. A stem generally grows in an upright position and contributes to the main structural support of a tree crown. If the diameter is measured at root collar, the number of stems is required.

DRC measured trees commonly have multiple stems. DRC-measured trees with stems clumped together and a unified crown and appearing to be from the same origin are treated as one tree. If necessary for diameter measurement, remove loose material on the ground but not mineral soil. For multi-stemmed DRC-measured trees with at least one stem ≥ 5.0 " at the root collar, DRC is computed as the square root of the sum of the squared stem diameters. For a single-stemmed tree, DRC is equal to the single diameter measured. For a multi-stemmed tree, DRC is calculated from the diameter measurements of all qualifying stems (≥ 1.5 " diameter and at least one foot in length).

Use the following formula to compute DRC. Record individual stem diameters in the tree form "REMARKS" column for future reference.

$$DRC = \sqrt{\sum_1^n (\text{stem diameter})^2}$$

Example: Tree #1 has three qualifying stems; 5.9, 2.4, and 1.5

$$DRC = \sqrt{(5.9)^2 + (2.4)^2 + (1.5)^2} = 6.5$$

When DRC is impossible or extremely difficult to measure with a diameter tape (e.g., due to thorns, extreme limbs, packrat's nest),

the stem(s) may be estimated to the nearest inch. Note "estimated DRC" in the tree form "REMARKS" column.

Accuracy Standards:

<.5 inch	No Errors
.5 inch - 13.9 inches	± 0.1 inch
14.0 inches - 23.9 inches	± 0.2 inch
24.0 inches - 34.9 inches	± 0.3 inch
35.0 + inches	± 0.5 inch
Borderline variable plot trees purpose of determining trees in or out)	± 1 inch (for the
Estimated DRC	± 1 inch



Measure at the ground line when reasonable.



Measure above butt swell.



Excessive diameter below stems. Measure each stem and compute DRC.



Multistemmed above diameter.



Measure missing stem(s) and compute DRC.



Multistemmed at or below ground. Measure each stem and compute DRC.

Height (maximum of 3 numbers)

Record tree height, in feet, from ground line on the uphill side to the uppermost tip. If the top is broken or missing, record the height to the break, and record the appropriate physical damage code. Tree heights are required for:

- Site Trees
- Growth Sample Trees
- Trees less than 4.5 feet tall. Does not apply to DRC species.
- All trees with broken or missing tops.

Additional tree heights should be measured and recorded when two adjacent sample trees of similar height can be viewed from the same vantage point, and when the height/diameter relationship of a particular tree seems atypical with respect to other trees of the same species.

Accuracy Standard: $\pm 10\%$
 $\pm 20\%$ for extensive and quick plot exams

Examples:

0.5 0.5 feet tall
23 22.5 - 23.4 feet tall

151

150.5 - 151.4 feet tall

Note: Trees less than ½ feet tall (0.5 feet) can be recorded to the nearest 1/10th foot. All trees over 0.5 feet are recorded to the nearest foot.

Total Tree Height

Measure from the base of the tree on the high ground side to the tip of the tree leader. Measure height from a point uphill or on the same contour line as the tree. Record total tree height to the nearest foot.

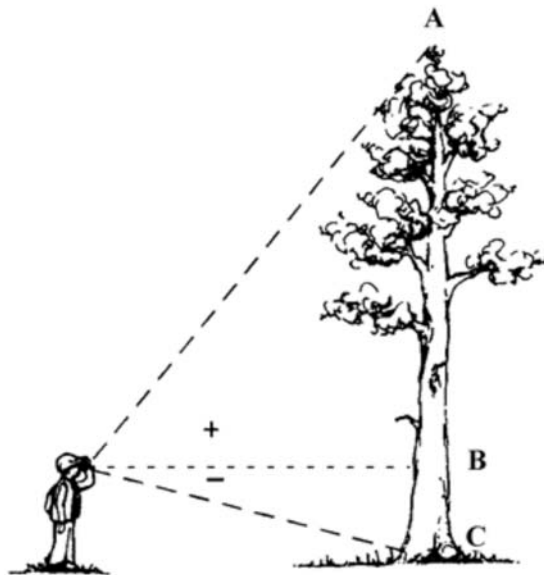

Leaning Trees

Trees leaning 25 percent (about 15°) or more from vertical require the following special height measuring technique.

Locate point on ground directly under tip of leaning tree. Measure height A B. Measure horizontal

distance B C. Determine actual tree height (AC) using either the Pythagorean theory for right triangles where:

$$\text{Tree Height} = \sqrt{AB^2 + BC^2}$$

Example: Measured height (AB) = 120'
 Horizontal distance (BC) = 40'

$$\text{Corrected tree height} = \sqrt{120^2 + 40^2} = 126.49$$

Or, use the following table:



Horizontal Distance - tip to center of bole at ground (B C)

MS HT	5	10	15	20	25	30	35	40	45	50	55	60	65	70	75	80	85	90
40	40	41	43	45														
50	50	51	52	54	56													
60	60	61	62	63	65	67												
70		71	72	73	74	76	78											
80		81	81	82	84	86	87	89										
90		91	91	92	94	95	97	98	101									
100		101	101	102	103	104	106	108	110	112								
110			111	112	113	114	116	117	119	121	123							
120			121	122	123	124	125	126	128	130	132	134						
130			131	131	132	133	135	136	138	139	141	143	145					
140			141	141	142	143	144	146	147	149	150	152	154	157				
150			151	151	152	153	154	155	157	158	160	162	164	166	168			
160			161	161	162	163	164	165	166	168	169	171	173	175	177	179		
170			171	171	172	173	174	175	176	177	179	180	182	184	186	188	190	
180			181	181	182	183	183	184	186	187	188	190	191	193	195	197	199	201
190				191	192	192	193	194	195	196	198	200	201	203	204	206	208	210
200				201	202	202	203	204	205	206	208	209	211	212	214	215	217	219

Forked Trees

If tree forks below DBH, treat as two trees and measure height of each stem from base of tree to tip of tree.

If the fork crotch occurs at or above 4.5 feet on high ground side, the tree is treated as a single tree. Measure height of the tallest fork.

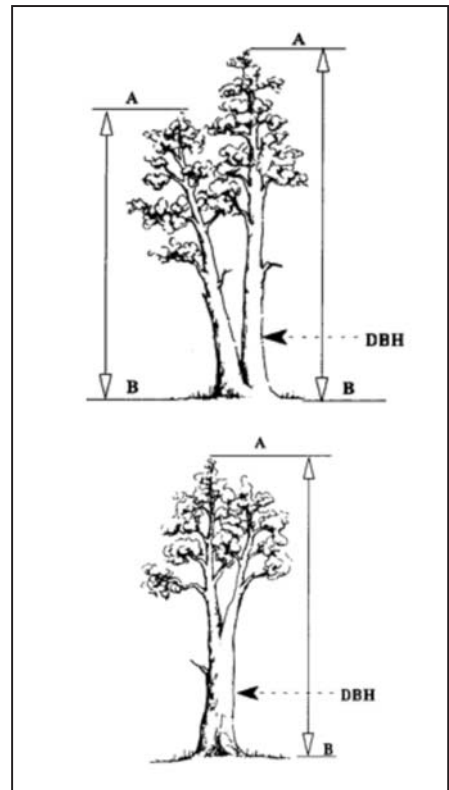

Forked Tree with a Broken Top

The height of the tallest fork is measured and recorded in the "Total Height" field. Record a tree damage of "broken top."

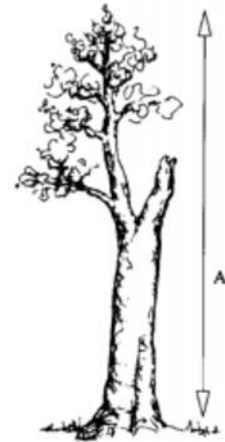

Trees with a Missing Top

Measure height of stub and record in the "Total Height" field. Record a tree damage of "missing top." If the tree is forked, measure the height of the stub of the dominant fork.



NEW MEXICO 
FOREST AND WATERSHED
RESTORATION INSTITUTE
AT NEW MEXICO HIGHLANDS UNIVERSITY