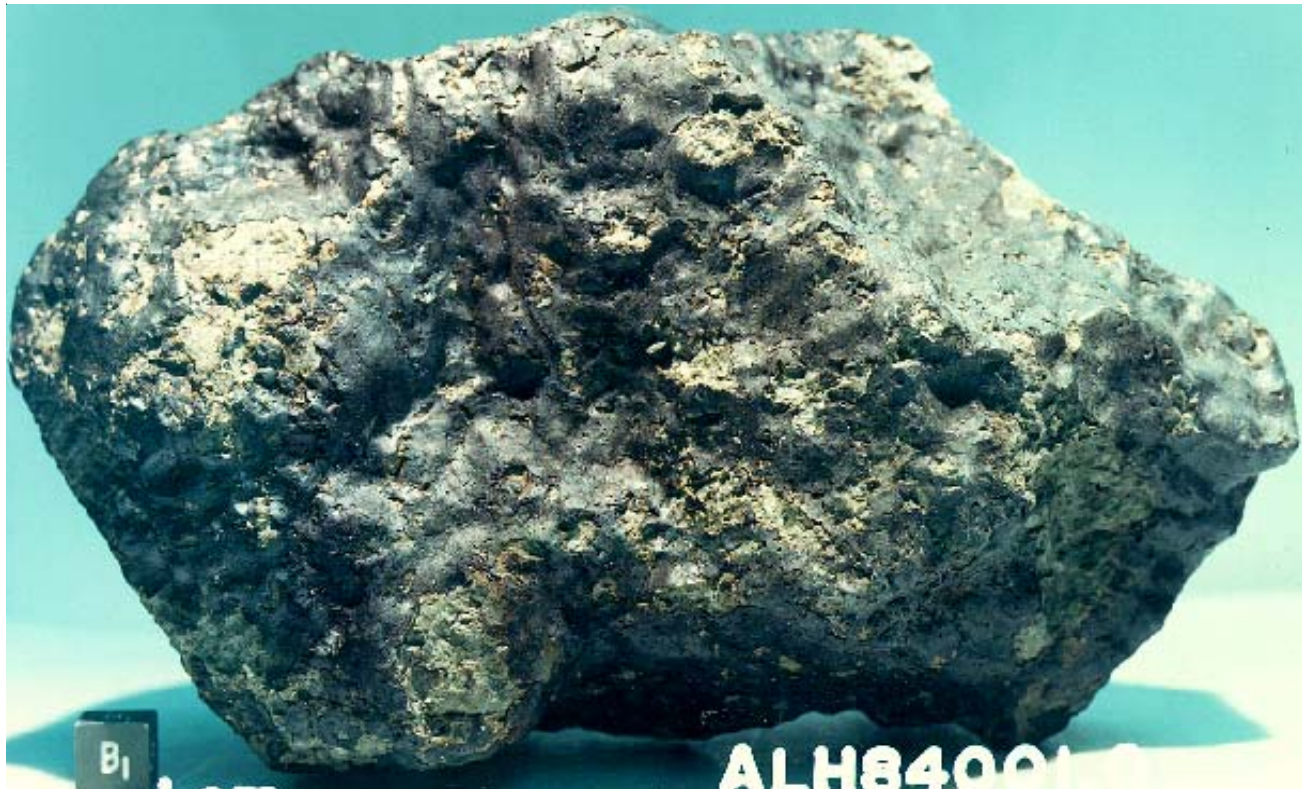


# ALH84001

Orthopyroxenite, 1931 grams



*Figure 1: Photograph of exterior surface of Martian meteorite ALH84001. The cube is 1 cm. (NASA # S85-39570)*

## **Introduction**

ALH84001 was found during a snowmobile ride December 27th, 1984 in the Far Western Icefield of Allan Hills and was picked up (*as sample number 1539*) without the usual careful photography. The ANSMET Field Notes describe it as a “*highly-shocked, grayish-green, achondrite, 90% covered with fusion crust (with the additional comment ‘Yowza-Yowza’)*.” Since it was recognized as the most unusual rock collected, it was the first Antarctic meteorite to be processed from the 1984-5 field season (Score 1997).

The fusion crust has spalled in some areas from the hackly end (W1), exposing a uniform coarse-grained rock with a greenish-gray color and a blocky texture (figures 1, 2) (Score and MacPherson 1985). During preliminary examination, Mason *et al.* (1992) noted cleavage planes on some large crystals and that the stone had a “shocked appearance.” ALH84001 was originally classified as a diogenite by Score and

MacPherson (1985) and Mason *et al.* (1992), although they noted “*patches of brown Fe-rich carbonate.*” Preliminary examination classified ALH84001 as weathering category A/B and fracturing category B (moderate cracks).

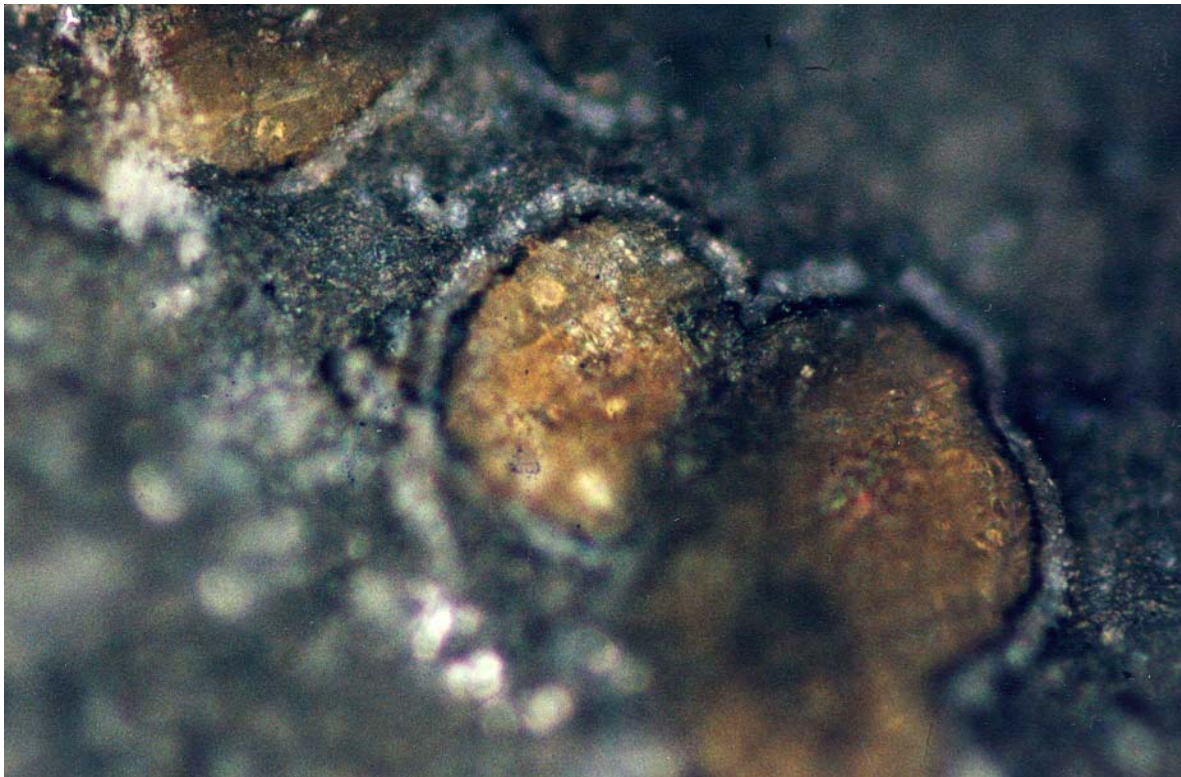
However, during a study of diogenites, Berkley and Boynton (1992) and Mittlefehldt (1993) noted that the chromite in ALH84001 contained substantial Fe<sup>+3</sup>. Mittlefehldt also noted that the rock contained pyrite rather than troilite and had unusual Fe/Mn for a diogenite. Finally, based on oxygen isotope analysis of Clayton (1993) and the above evidence, ALH84001 was reclassified as a Martian meteorite (Score and Mittlefehldt 1993; Mittlefehldt 1994).

As explained below, this Martian meteorite has been found to have a very old age (~ 4.5 to 4.0 b.y.), but it has suffered several impact events during its history, as evidenced by annealed granular bands and isotropic plagioclase, making age determinations difficult to





**Figure 2:** Photograph of exterior surface of Martian meteorite ALH84001. Note the large cavity on this surface. The cube is 1 cm. (NASA # S85-39567)

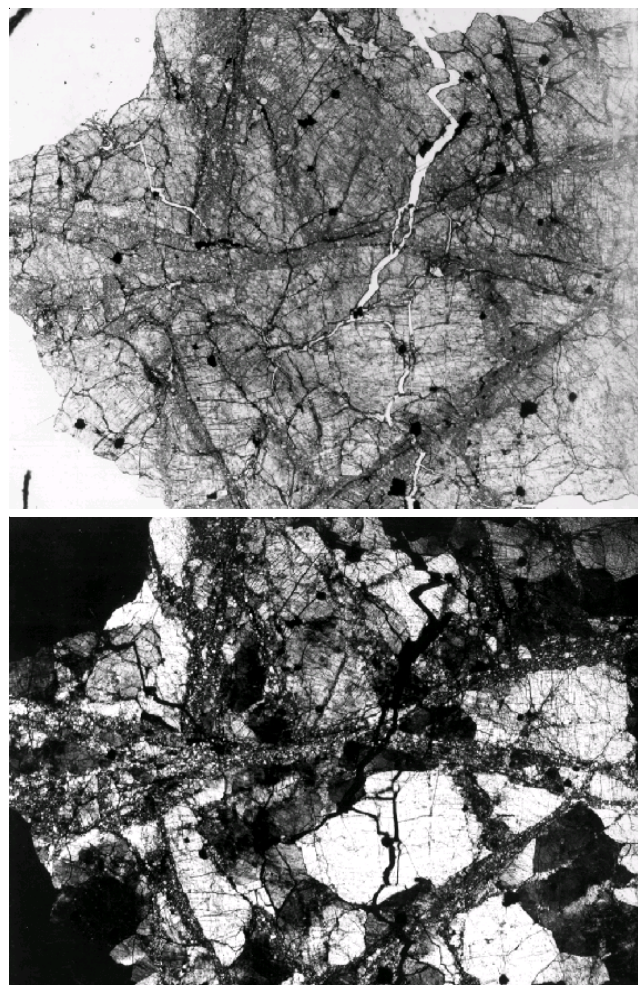


**Figure 3:** Close-up photograph of a small piece of Martian meteorite ALH84001 illustrating rounded carbonate inclusions with orange interiors and black-white-black rims. Size of round inclusion is ~100-200 microns. This photo, by Monica Grady, was originally published in *Nature* 374, 616. (NASA photo # S95-00690)



interpret. This sample also has an unusually old cosmic-ray, exposure age (~15 m.y.) for Martian meteorites (figure I-13).

A most unusual feature of this rock is the presence of small (100-200 microns), fine-grained, spheroidal areas (called “rosettes”) of zoned Mg-Fe-Mn-Ca carbonate (figure 3). Thomas *et al.* (1995, 1996) and Romanek *et al.* (1995) proposed that organic matter and small magnetite grains associated with the outer rims of these carbonate spheroids may have a biological origin. In August 1996, D. McKay and eight co-authors published their evidence of past biological activity on Mars preserved within the outermost black rims of the carbonate globules of this sample (*see section on*



**Figure 4:** Plane polarized and cross-polarized photomicrographs of same area of thin section ALH84001,64 illustrating the crushed zones in the large orthopyroxene grains (field of view is 6 mm). Photographs provided by Mittlefehldt (originally published in *Meteoritics* 29, 215).

“*Biogenic Hypothesis*” below). Consequently, NASA was asked to “*put its full intellectual power and technological prowess behind the search for further evidence of life on Mars*” (Kerr 1996). (see footnote)

ALH84001 appears to be the first Martian rock studied in detail where the effects of both alteration and shock have been studied together. A key observation was that the cracks in some carbonate rosettes were offset by a shock event, demonstrating that the secondary alteration must have occurred on Mars (*see below*). Another key observation is that there is more than one generation of carbonate deposition (Corrigan *et al.* 2003).

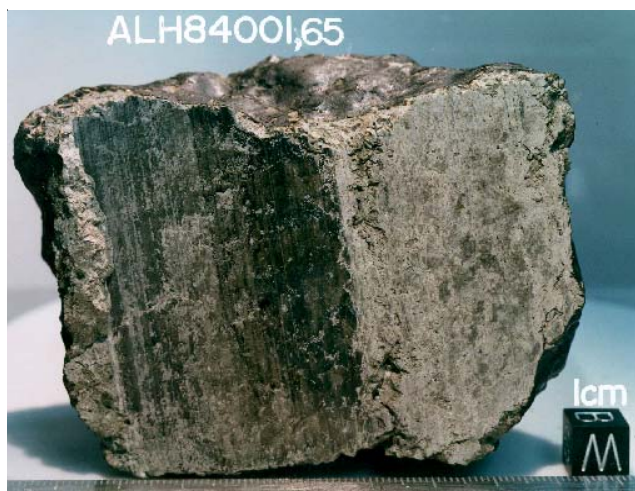
Review papers by McSween (1997), Gibson *et al.* (1997), Gleason *et al.* (1997), Treiman (1998, 2003), Kring *et al.* (1998) and Papike *et al.* (2009) give the reader a framework for what follows. One finds that there is not a lot of agreement between research teams that have studied the various features of ALH84001, but it should be pointed out that each research team has received only a small portion of the sample and ALH84001 is by no means homogeneous on such a small scale. (see footnote)

### **Petrography**

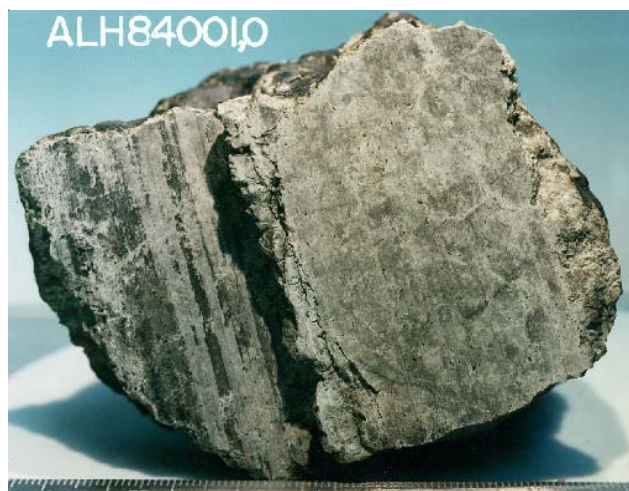
ALH84001 is a coarse-grained, cataclastic orthopyroxenite (97% orthopyroxene, 2% chromite, ~1% maskelynite, 0.15% phosphate) with minor augite, olivine, pyrite and secondary Fe-Mg-Mn-Ca carbonate. The igneous minerals are essentially unzoned whereas the carbonate is highly zoned in composition. Mason *et al.* (1992) described a thin section with “*orthopyroxene crystals up to 5 mm long forming a polygonal-granular mosaic*” (figures 4a, b). Berkley and Boynton (1992) reported orthopyroxene grains up to 6 mm, which commonly join in 120° triple junctions (Mittlefehldt 1994a). Chromite is found as euhedral inclusions in the orthopyroxene. Minor maskelynite, chromite and phosphate are found at the interstices. Minute olivine inclusions in orthopyroxene occur as clusters adjacent to disrupted carbonate globules and feldspathic shock glass (Shearer *et al.* 1999).

---

**Footnote:** This sample has been the subject of considerable controversy, which can be best summarized by two hypotheses termed “*Biological Hypothesis*” and “*Abiotic Hypothesis*” - discussed below.



**Figure 5:** Photograph of sawn surface of Martian meteorite ALH84001,65 illustrating the porosity of the interior of the sample. (NASA # S94-32547)



**Figure 6:** Photograph of sawn surface of Martian meteorite ALH84001,0 after the second sawcut illustrating the porous “crushed” zone in the middle of the sample where the break occurred during sawing. (NASA # S94-32548).

Macroscopic description of hand specimen ALH84001,65 by Mittlefehldt (1997) revealed that granular bands within the orthopyroxenite were cut by old, pre-terrestrial fractures. The granular bands can be distinguished by (1) deformed chromites, often forming stringers, (2) streaks of light and dark silicates, and (3) a sugary texture. These bands are roughly planar, but there is no preferred orientation. Mittlefehldt also observed that old fracture surfaces cross-cut granular bands and noted that these old fracture surfaces are distinguishable by, (1) transecting more than one pyroxene grain, (2) a general gently undulating shape, (3) a waxy appearance, and (4) a fine-scale, wavy structure similar to ‘slickensides’ in appearance. Thin, round to elliptical, disks of color-zoned carbonate were found to be prevalent along the old fractures. From these observations Mittlefehldt concluded that the sequence was, (1) formation of the granular bands, (2) formation of the old fracture surfaces, and (3) deposition of the rounded, zoned carbonate blebs. Thin sections of ALH84001 contain mm-wide bands of crushed and annealed orthopyroxene with a fine granular texture and grain size 10-30 microns (Treiman 1995b). The offset along these granular bands is indicated by the length of sheared chromites (several 100 microns).

Photographs of the large sawn surface through the center of ALH84001 (figures 5, 6) reveal a centimeter-wide light-colored zone in the center of the rock that has become known (*for allocation purposes*) as the “crushed zone”. Photos of this centimeter-wide band show that it has ~5-10 % elongate cavities (possibly

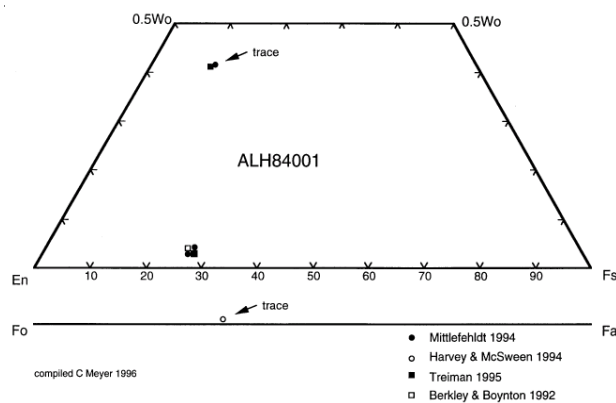
interconnecting). Thomas *et al.* (1995) illustrate a SEM photo of an interior surface of a cavity in this band. Gleason *et al.* (1997) found a slight difference in the trace element composition of this “zone”(figure 10). However, Mittlefehldt (personal communication) found nothing unusual about the appearance of this region of the rock in his examination of the hand specimen (1997).

Away from this central zone, the porosity of the main part of the rock is only 1-2% and apparently non-penetrating. A few mm-size vesicles or voids can be seen in the photos of the sawn surface (figures 5, 6).

The presence of small patches of carbonates along annealed fractures in ALH84001 has led to numerous studies. In thin section, some of these carbonates appear to be replacing maskelynite (Treiman 1995b; Kring *et al.* 1998). An important debate has been whether these carbonates formed at high or low temperature (Harvey and McSween 1996; D. McKay *et al.* 1996; Valley *et al.* 1997 and Treiman and Romanek 1998). The issue of apparent metasomatism that must have accompanied the CO<sub>2</sub> alteration of this rock has been studied by Mittlefehldt and Lindstrom (1994a), Wadhwa and Crozaz (1994c, 1995b), Treiman (1995b) and Griffith and Shock (1995) (*see the section on “Carbonate Rosettes”*).

In summary, detailed petrography of thin sections of ALH84001 shows that, after cooling in an igneous plutonic environment, ALH84001 was subjected to at





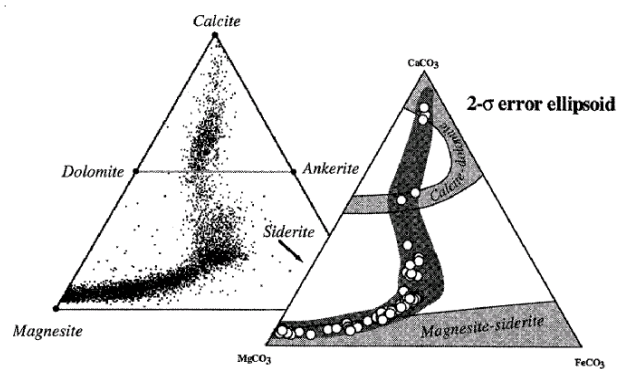
**Figure 7:** Composition diagram for pyroxene in ALH84001. Only trace olivine and augite is present, with most of the sample orthopyroxene. Data replotted from Berkley and Boynton (1992), Mittlefehldt (1994), Harvey and Treiman (1994) and Treiman (1995).

least two shock events as well as alteration in a CO<sub>2</sub>-rich fluid (Mittlefehldt 1994a; Treiman 1995b; Gleason *et al.* 1997; G. McKay *et al.* 1998; Treiman 1998; Greenwood and McSween 2001). However, Scott *et al.* (1998) concluded only one shock event is evident in the samples studied by them and pointed out that a sequence of events can occur in an instant (geologically speaking) during and immediately after an impact event. It seems clear that this rock has had a long and varied history (since about 4.5 b.y.) on the surface of an active planet (Mars) (*see below*).

SEM studies by Wentworth and Gooding (1995) and Wentworth *et al.* (1998) found that the fusion crust of ALH84001 is fresh and unaltered, although preliminary examination assigned the sample weathering category A/B. From the density of nuclear tracks, Goswami *et al.* (1997) have concluded that the outer 5 centimeters was ablated away during entry into the Earth's atmosphere.

### **Mineral Chemistry**

**Orthopyroxene:** Mason *et al.* (1992) and Berkley and Boynton (1992) reported orthopyroxene crystals up to 5-6 mm long. The orthopyroxene in ALH84001 (figure 7) is homogeneous in composition (En<sub>70</sub>Wo<sub>3</sub>) and no pyroxene exsolution lamellae were observed (Berkley and Boynton 1992; Mittlefehldt 1994a; Treiman 1995b). Papike *et al.* (1994) and Wadhwa and Crozaz (1994, 1998) have determined the REE in the orthopyroxene and calculated the composition of magma that would be in equilibrium. However, Treiman (1996a) pointed out that it is not possible to calculate the composition of



**Figure 8:** Composition diagrams for carbonates in Martian meteorite ALH84001. This is figure 3 in Harvey and McSween (1996).

the original magma using equilibrium partition coefficients, since the sample has certainly undergone subsolidus equilibration.

Domeneghetti *et al.* (2007) have determined the closure temperature of 530 °C of the Fe<sup>+2</sup>-Mg ordering process in orthopyroxene in ALH84001 – possibly related to one the impact events discussed by Treiman (1998).

**Olivine:** Minor olivine (Fo<sub>65</sub>) is present (Harvey and McSween 1994; Shearer and Leshin 1998; Shearer and Adcock 1998) as minute inclusions in orthopyroxene. Harvey and McSween (1996) also reported trace olivine in the crushed zones. A detailed, careful study by Shearer *et al.* (1999) of ~100 minute (<40 μm) olivine inclusions in orthopyroxene showed that they were generally located adjacent to carbonate globules (and/or feldspathic shock glass). *Note that the olivine reported by Sack *et al.* (1991) is of a mislabeled sample of EETA79002 diogenite.*

**Maskelynite:** Maskelynite (An<sub>35</sub>Or<sub>3</sub>) or “plagioclase glass” is only a minor phase in ALH84001 (Mason *et al.* 1992; Berkley and Boynton 1992; Mittlefehldt (1994a). Mittlefehldt found that some maskelynite analyses had excess Si, inferring that the original plagioclase may have been intergrown with SiO<sub>2</sub>. Wadhwa and Crozaz (1994) determined the REE abundance in maskelynite. However, Scott *et al.* (1997a, b) found that the “maskelynite” in this sample is rather “*plagioclase glass*” that has flowed into cracks. Greenwood and McSween (1998, 2001) reported analyses of “*mixed feldspar glass*” and “*mobilized plagioclase glass*” as well as stoichiometric maskelynite. Brearley (1998), Treiman and Treado (1998) and Shearer and Adcock (1998) also

report on the composition and distribution of shocked feldspar glass in ALH84001. Micro-Raman spectra by Cooney *et al.* (1999) indicates “*post-shock annealing and melting*”.

**K-feldspar:** Turner *et al.* (1997) and Greenwood and McSween (1998, 2001) reported the composition of rare “sanidine glass” (~ Or<sub>52</sub>).

**Chromite:** Euhedral grains of chromite occur as inclusions in the orthopyroxene and in the interstices. Some chromite is found as “schlieren” in the sheared, granular zones. Berkley and Boynton (1992), Mittlefehldt (1994a) and Gleason *et al.* (1997) correctly identified the presence of significant Fe<sup>+3</sup> in chromite based on calculations applied to precise electron probe analyses. The Fe<sub>2</sub>O<sub>3</sub> content of ALH84001 chromite is ~ 5.3 wt. % based on 6 analyses by Berkley and Boynton (1992) and 7.7 wt. % based on 103 analyses by Mittlefehldt (1994).

**Phosphates:** Minor apatite (~300 microns) occurs as interstitial grains (Wadhwa and Crozaz 1994, 1995b; Mittlefehldt 1994a). Large grains (up to 800 microns) of merrillite have been analyzed by Boctor *et al.* (1998a, b) for D/H. Cooney *et al.* (1998, 1999) obtained micro-Raman and infrared reflectance spectra of chlorapatite and merrillite, showing that they were anhydrous. Wadhwa and Crozaz (1998) have determined the REE pattern for merrillite. Greenwood *et al.* (2003) have determined the oxygen isotopic composition of both phosphates and determined their chemical composition. Terada *et al.* (2003) were able to date the phosphates in ALH84001.

**Carbonates:** (see also section on “Carbonate Rosettes” below) According to Romanek *et al.* (1994a, 1995) about 1% of ALH84001 is orange-colored carbonate, however, the carbonate is heterogeneously distributed and the amount of carbonate in the rock as a whole appears to be very minor and may actually be considerably less than 1% (Dreibus *et al.* 1994 estimated 0.46%). (see footnote)

Carbonate in ALH84001 occurs in several habits (McKay *et al.* 1997; Scott *et al.* 1998; Kring *et al.*

1998; Corrigan *et al.* 2004). Some carbonate is found as an interstitial filling in cracks (Mason *et al.* 1992). Another occurrence is as minute “*thin pancakes*” found attached to broken surfaces (D. McKay *et al.* 1996; Scott *et al.* 1998).

Most interesting, perhaps, are the interstitial carbonate clusters, known as “rosettes”, (~100-200 microns in size) usually associated with maskelynite (possibly as “replacement” of maskelynite (Treiman 1995b) and/or orthopyroxene (Mittlefehldt 1994a). These carbonate “rosettes” are zoned, from Ca- and Fe-rich to Mg-rich (Harvey and McSween 1995, 1996; G. McKay and Lofgren 1997; Scott *et al.* 1997, 1998; Gleason *et al.* 1997). Zoning is oscillatory, with two pronounced black zones (Fe-rich) sandwiching a white Mg-rich zone. (see footnote) These carbonate grains appear to pre-date the last shock event as evidenced by offset fractures (Mittlefehldt 1994a) and mobilized “plagioclase glass” intruding the carbonates (Schwandt *et al.* 1999). Harvey and McSween (1995, 1996) and Treiman (1995b) report analyses of the carbonate “rosettes” (figure 8). Mason *et al.* (1992) and others reported the average analysis of the carbonate as (Fe<sub>29</sub>Mg<sub>60</sub>Ca<sub>11</sub>)CO<sub>3</sub>. Romanek *et al.* (1995) describe the carbonates as “*spheroidal aggregates or fine-grained vug-filling structures.*”

The carbonate “rosettes” also exhibit considerable Mn/Fe zonation. D. McKay *et al.* (1996) reported an inner core of Mn-enriched, Ca-carbonate in one “rosette” (see also analyses for Mn by Treiman 1995b). Further details of the carbonate zonation are reported by G. McKay and Lofgren (1997), Scott *et al.* (1997) and Gleason *et al.* (1997). G. McKay *et al.* (1998) show narrow cracks in plagioclase glass filled with carbonate, where the zonation along the carbonate in the crack is similar to that in carbonate globules, and presumably of the same generation. Wadhwa and Crozaz (1995b) have reported the REE contents for carbonates.

Sugiura and Hoshino (2000) and Eiler *et al.* (2001, 2002) found that high temperature (>500 °C) release

---

**Footnote:** *Cursory examination of all thin section of ALH84001, by this compiler, showed that at least some carbonate was present in every section.*

---

**Footnote:** *It is the observation of this compiler, that the exact nature of the black rims on the carbonate “rosettes” has not been properly characterized, which is surprising, considering that it is where the claim of evidence for life in this rock is to be found.*

of water from carbonates is greatly enriched in deuterium (*Martian atmosphere?*).

**Silica:** Silica has been observed in a variety of locations in ALH84001. Silica (phase unknown) has been reported in the centers of some of the carbonate areas where the magnesite rims come together (Harvey and McSween 1995, 1996). Original igneous silica-plagioclase intergrowth is also inferred from Si-rich maskelynite analysis (Mittlefehldt 1994a). Silica patches in orthopyroxene were reported by Valley *et al.* (1997), Scott *et al.* (1997) and Turner *et al.* (1997). Valley *et al.* also studied a thin “silica vein” cutting across a “carbonate concretion”. Greenwood and McSween (2001) give analyses of “silica glass” which they believe was shock mobilized. Cooney *et al.* (1999) used micro-Raman spectroscopy to show that the silica glass they studied was amorphous.

Westall *et al.* (1998) and Greenwood and McSween (2001) describe an amorphous silica coating on the internal surfaces where the carbonate globules are found. They find that this silica film postdates the secondary fracturing of the carbonate globules and is evidence that “low-temperature, silica-rich, hydrothermal fluids” percolated through the rock. G. McKay *et al.* (1998) and Schwandt *et al.* (1999) described a set of very fine, “web-like” veins of “silica” occupying the interstices between angular or slightly rounded fragments of feldspar and concluded this is evidence for fluid transport and deposition. Valley *et al.* (1997) reported that silica glass had  $\delta^{18}\text{O} = +20.4$  ‰ (out of equilibrium with orthopyroxene, but similar to that of carbonate). (*Precise determination of  $\Delta^{17}\text{O}$  is needed to tell if atmospheric oxygen has been added to the silica – see Farquhar *et al.* 1998*)

**Sulfides:** Pyrite grains (10-40 microns) have been reported associated with interstitial chromite, maskelynite and/or carbonate “rosettes” by Mittlefehldt (1994a) and Treiman (1995b). The pyrite in ALH84001 appears to be secondary in nature and is primarily found in impact-produced granular bands (Greenwood *et al.* 2000). Extremely fine-grained sulfides (~100 nm) are found in the black rims on the carbonate clusters (D. McKay *et al.* 1996). Some of the fine-grained sulfide is identified as pyrrhotite and some is tentatively identified as “greigite” (D. McKay *et al.* 1996). Wentworth and Gooding (1995) reported minute, delicate, feathery grains of ZnS within the carbonate clusters. Shearer *et al.* (1996a, b), Greenwood *et al.*

(1997a, b) and Boctor *et al.* (1998) reported isotopic data for sulfur for some of the larger grains of pyrite. Greenwood *et al.* (2000) found significant, non-mass-dependent  $\Delta^{33}\text{S}$  anomalies in two pyrite grains (*see section on “Other Isotopes”*).

**Augite:** Minor augite ( $\text{En}_{45}\text{Wo}_{43}$ ) has been reported by Treiman (1995b) (figure 7). It is found in interstitial regions associated with maskelynite and apatite.

**Glasses:** Thomas *et al.* (1996) and Bell *et al.* (1999) reported three types of glass: 1) maskelynite, 2) melted orthopyroxene and 3)  $\text{SiO}_2$ . G. McKay and Lofgren (1997), Scott *et al.* (1997) and Greenwood and McSween (1998, 2001) reported “plagioclase glass” and “mixed feldspar glass”. Brearley (1998), Schwandt *et al.* (1999) and others have observed that feldspathic glass was remelted and remobilized after formation of the carbonate. However, Greenwood and McSween have argued that the “mixed feldspar glass” in the shear zones, preceded the carbonate deposition. Barber and Scott (2001) observed orthopyroxene glass within orthopyroxene and in fractured-filling carbonate.

**Magnetite:** Fine-grained magnetite (~10-75 nm) has been reported in the Fe-rich rims of the carbonate spheroids (Thomas *et al.* 1996; D. McKay *et al.* 1996; Golden *et al.* 1997; Thomas-Keprta *et al.* 1998)(figure 20). D. McKay *et al.* claim that these small magnetite grains “did not contain detectable amounts of minor elements” and that they “are single-domain crystals having no structural defects.” Bradley *et al.* (1996, 1997, 1998) found that the morphologies and defect structures of magnetite grains that they studied “are inconsistent with a biogenic origin.” They report whiskers of magnetite and nanocrystals of magnetite that are epitaxially intergrown with one another and the carbonate substrate upon which they are deposited. Thomas-Keprta *et al.* (2000, 2001) have extracted ~six hundred small magnetite grains from the carbonates and studied their morphologies (about 400 were irregular-shaped, 164 were elongated prisms and 41 were whisker-like). The elongated prisms were found to be “chemically and physically identical to terrestrially, biologically-precipitated, intracellular magnetites produced by magnetotactic bacteria strain MV-1”. Magnetite as a product of biomineralization is reviewed by Chang and Kirschvink (1989). Devouard *et al.* (1998) and others have studied magnetite from terrestrial magnetotactic bacteria.

Blake *et al.* (1998) also report epitaxial or near-epitaxial orientation of magnetite with host carbonate which is suggestive of an inorganic origin. Brearley (1998) proposed an origin of fine grain magnetite in ALH84001 by partial thermal decomposition of siderite.

**Hematite:** Steele *et al.* (2008) have recently reported hematite in the interior portions of both the carbonate globules and the slab carbonates based on Raman spectroscopy.

**Periclase:** Barber and Scott (2002) reported periclase occurring in 1 micron-sized patches of magnesite as profuse grains 3 nm in size and also as 30-50 nm sized crystals associated with voids in the carbonate. “Brucite” has also been reported by Treiman and Keller (2000).

**Hydrous silicates:** The general absence of hydrous silicates in this meteorite was initially noted by several researchers (Mittlefehldt 1994a; Harvey and McSween 1994; Treiman 1995b; Wentworth and Gooding 1995). However, Thomas-Keprta *et al.* (1997) and Wentworth *et al.* (1998) reported “individual packets (nm-sized) and relatively large regions (~400 x 500 nm in size) of phyllosilicates in the orthopyroxene regions found near some carbonate globules. The basal spacings measure 10-11 Å suggesting this is a smectite-type clay”. Brearley (1998c, 2000) has reported small grains of “phlogopite”, both within carbonate and/or closely associated with it. Hydrous silicates should be abundant, if the carbonates in this rock are the product of “hydrothermal” reaction (Griffith and Shock 1995, 1997; Warren 1998).

**Salts:** Wentworth and Gooding (1995) and Wentworth *et al.* (1998) reported trace amounts of Fe-sulfate, a possibly hydrated form of Mg-carbonate, patches of amorphous silica with micron-sized grains of NaCl and a single Ca-sulfate crystal. They found that the fusion crust of ALH84001 is among the least weathered of any Antarctic meteorites.

### **Whole-rock Composition**

Dreibus *et al.* (1994), Gleason *et al.* (1997), Warren and Kallemeyn (1996, 1997), Warren *et al.* (1999) and Kong *et al.* (1999) give complete analyses of ALH84001 (table 1 a, b). They found that ALH84001 is a very mafic rock with high Mg/Fe ratio. Mittlefehldt (1994a) and Wang *et al.* (1998) also reported INAA and RNAA

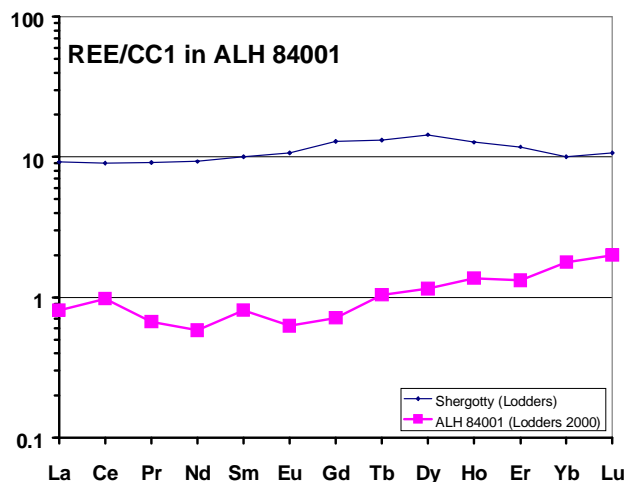
analysis of ALH84001 (figure 9). Dreibus *et al.* noted the relatively high concentration of “volatile” elements (particularly Zn = 106 ppm). However, Jovanovic and Reed (1987) reported only 14 ppb Hg.

Warren and Kallemeyn (1996), Ebihara *et al.* (1998), Warren *et al.* (1999) and Kong *et al.* (1999) found that ALH84001 has extremely low Ni, Ir, Au, Re and Os, as compared with other Martian meteorites. From this data, they model an old Martian mantle, depleted in siderophile elements.

Gleason *et al.* (1997) found a significant difference in the trace element pattern for the “crushed” central zone from the bulk rock (figure 10).

### **Radiogenic Isotopes**

Ash *et al.* (1996) initially determined a shock age by  $^{39}\text{Ar}/^{40}\text{Ar}$  of  $4.0 \pm 0.1$  b.y. based on the Ar released above 400 °C. Their plateau age from maskelynite was 4.1 - 4.2 b.y. (figure 11). Bogard and Garrison (1997, 1999) determined an apparent “plateau” age of  $4.1 \pm 0.2$  b.y., but argued that this is critically dependent on the type of Ar correction that is applied (figure 12). A “preferred” age of  $4.18 \pm 0.12$  b.y. was calculated, based on the assumption that  $^{36}\text{Ar}$  is terrestrial. Turner *et al.* (1997) determined an “average  $^{39}\text{Ar}/^{40}\text{Ar}$  age” of  $3.92 \pm 0.10$  b.y., but stated that the “true value lies somewhere between 4.05 b.y. and 3.8 b.y.” depending on the type of data correction that is chosen. Ilg *et al.* (1997) determined  $4.07 \pm 0.04$  b.y. by Ar laser probe.



**Figure 9:** Normalized rare earth element diagram for ALH84001 and for Shergotty (data from Lodders 1998).



**Table 1a. Chemical composition of ALH84001.**

reference weight	Mittlefehldt94 251 mg	Dreibus94	Dreibus94 236 mg	Dreibus94 71 mg	Warren96	Warren96	Warren97 337 mg	Warren97 332 mg
SiO2		52.7	(d)		52.84		52.93	52.93
TiO2		0.2	(d)		0.2	(a)	0.2	0.2
Al2O3	17	(a) 1.25	(d)		1.21	(a)	1.21	1.21
FeO		17.6	(d)	17.6	(a)	17.24	(a)	17.23
MnO				0.443	(a)	0.47	(a)	0.47
CaO	2.5	(a) 1.82	(d)	1.7	(a)	1.82	(a)	1.82
MgO		24.5	(d)		24.7	(a)	24.7	24.7
Na2O	0.0867	(a)		0.162	(a)	0.135	(a)	0.145
K2O	0.013	(c)	0.026	(d)	0.022	(a)	0.015	(a)
P2O5				0.014	(e)			0.015
<b>sum</b>		<b>98.1</b>			<b>98.63</b>		<b>98.72</b>	<b>98.85</b>
Li ppm		580	(d)					
Cl								
Sc	12.4	(a)		12.7	(a)	11.8	(a)	11.8
V					205	(a)	205	205
Cr	6842	(a)		8498	(a)	7300	(a)	7300
Co	46.3	(a)		43	(a)	44.6	(a)	45
Ni				<20	(a)	<12	(a)	5.8
Zn				106	(a)	82	(a)	97
Ga				3.2	(a)	2.74	(a)	2.74
Ge							1.08	(b) 1.08
As				<0.08	(a)	<0.025	(a)	
Se				<0.4	(a)	<0.163	(a)	<0.17
Rb					0.83	(e)		<7.8
Sr					4.46	(e)		<24
Y					1.63	(e)		
Zr					5.89	(e)		<38
Nb					0.42	(e)		
Mo								
Pd ppb								
Ag ppb								
Cd ppb								
In ppb						77	(b) 77	
Sb ppb								
Te ppb								
Cs ppm					0.04	(e)		<0.05
Ba					4.03	(e)		<28
La	0.158	(a)		0.13	(a)	0.15	(e)	0.246
Ce					0.43	(e)	0.65	(a)
Pr					0.06	(e)		
Nd					0.265	(e)		<0.9
Sm	0.107	(a)		0.1	(a)	0.104	(e)	0.16
Eu	0.023	(a)		0.036	(a)	0.032	(e)	0.049
Gd					0.14	(e)		
Tb	0.036	(a)		0.04	(a)	0.03	(e)	0.043
Dy				0.27	(a)	0.24	(e)	<0.56
Ho				0.07	(a)	0.068	(e)	0.3
Er					0.21	(e)		0.07
Tm					0.036	(e)		
Yb	0.27	(a)		0.31	(a)	0.255	(e)	0.262
Lu	0.045	(a)		0.051	(a)	0.037	(e)	0.042
Hf	0.12	(a)		0.17	(a)	0.16	(e)	0.117
Ta				<0.04	(a)		<0.042	(a)
W ppb								
Re ppb							0.0017	(b) 0.0017
Os ppb							0.0102	(b) 0.0102
Ir ppb				<2	(a)		0.08	(b) 0.08
Au ppb				1	(a)		0.0094	(b) 0.0094
Tl ppb								<2.2
Bi ppb								<0.64
Th ppm				<0.06	(a)	0.035	(e)	<0.047
U ppm				0.012	(a)	0.01	(e)	<0.05

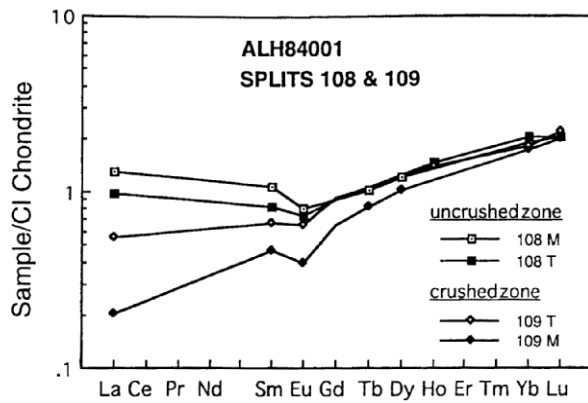
technique: (a) INAA, (b) RNAA, (c) Middlefehldt 94b, (d) XRF, (e) spark source mass spec.

**Table 1b. Chemical composition of ALH84001(continued).**

reference weight	Gleason 97	Lodders 1998 averages	Warren 99 327 mg.	Warren 99 322 mg.	Kong 99 101 mg.	Wang 98	Wang 98
SiO <sub>2</sub>	50.3 (a)	52.8		52.84			
TiO <sub>2</sub>	0.22 (a)	0.21		0.2 (a)	0.25 (a)		
Al <sub>2</sub> O <sub>3</sub>	1.38 (a)	1.29		1.21 (a)	1.3 (a)		
FeO	18.4 (a)	17.5	17.27	(a) 17.37	(a) 18.21		
MnO	0.455 (a)	0.46	0.47	(a) 0.47	(a) 0.51		
CaO	1.77 (a)	1.82	1.82	(a) 1.8	(a) 2.01		
MgO	26.1 (a)	25		24.7	(a) 24.21		
Na <sub>2</sub> O	0.132 (a)	0.14	0.14	(a) 0.15	(a) 0.2		
K <sub>2</sub> O	0.015 (a)	0.017	0.015	(a) 0.014	(a) 0.03		
P <sub>2</sub> O <sub>5</sub>		0.014					
<b>sum</b>	<b>98.77</b>						
Li ppm							
C		580					
S		110					
Cl		8					
Sc	13 (a)	13	11.8	(a) 13.1	(a) 13.4		
V	197 (a)	201		205	(a) 207		
Cr	8140 (a)	7760	7300	(a) 8000	(a) 8100		
Co	48.9 (a)	47	45	(a) 50	(a) 51.6	(a) 32.8	(b) 17.4 (b)
Ni		5.8	5.8	(b) 6	(b) 2.6		
Zn	91.6 (a)	92	90	(b) 86	(b) 103	(a) 82.8	(b) 97.8 (b)
Ga	3.24 (a)	2.9	2.74	(a) 2.3	(a) 5.7	(a) 2.73	(b) 2.93 (b)
Ge		1.08	1.08	(b) 1.14	(b)		
As		<0.03	<0.03	(a)			
Se		<0.16	<0.17	(a) <0.23	(a)	0.232	(b)
Br			0.07	(a)			
Rb		0.83				0.297	(b) 0.342 (b)
Sr		4.5		<24	(a)		
Y		1.6					
Zr		5.9		<38	(a)		
Nb		0.42					
Mo					0.0053 (b)		
Ag ppb					<0.9	(b) 0.22	(b) 0.35 (b)
Cd ppb		77	<77	(b)		108	(b) 113 (b)
In ppb						21.7	(b) 23.8 (b)
Sb ppb						0.77	(b) 0.85 (b)
Te ppb						<0.5	(b) 1.5 (b)
Cs ppm	0.045 (a)	0.043		<0.05	(a)	0.0226	(b) 0.0219 (b)
Ba		4					
La	0.185 (a)	0.19	0.25	(a) 0.28	(a) 0.27		
Ce		0.59	0.65	(a) 0.7	(a) 0.3		
Pr		0.06					
Nd		0.265		<0.09	(a)		
Sm	0.114 (a)	0.12	0.16	(a) 0.163	(a) 0.14		
Eu	0.04 (a)	0.035	0.049	(a) 0.045	(a) 0.0556		
Gd		0.14			0.17		
Tb	0.039 (a)	0.038	0.043	(a) 0.042	(a) 0.062		
Dy	0.31 (a)	0.28	<0.56	(a) <0.7	(a)		
Ho	0.081 (a)	0.076		0.07	(a)		
Er		0.21					
Tm		0.036					
Yb	0.317 (a)	0.29	0.262	(a) 0.3	(a) 0.347		
Lu	0.053 (a)	0.049	0.042	(a) 0.05	(a) 0.0601		
Hf	0.18 (a)	0.14	0.117	(a) 0.111	(a) 0.2		
Ta	0.032 (a)	0.032	<0.042	(a) <0.06	(a)		
W ppb	79 (a)	79			<67	44.9	(f)
Re ppb		0.002	0.00166	(b) 0.00134	(b)		
Os ppb		0.01	0.0102	(b) 0.0122	(b) 0.16		
Pt ppb					2.3		
Ir ppb		0.08	0.08	(b) 0.108	(b) 0.0061		
Au ppb		0.009	0.0094	(b) 0.0095	(b) 0.0727	(b) 0.0077	(b) 0.04 (b)
Tl ppb						0.1	(b) 0.1 (b)
Bi ppb						<0.11	(b) <0.14 (b)
Th ppm		0.035	<0.05	(a) 0.11	(a)		
U ppm		0.011	<0.32	(a) <0.03	(a)	0.0094	(b) 0.0102 (b)

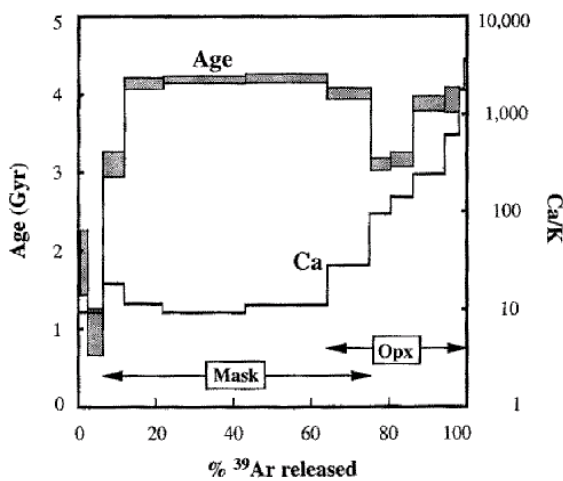
technique: (a) INAA, (b) RNAA, (c) Middlefehldt 94b, (d) XRF, (f) ther. ion. mass spec.



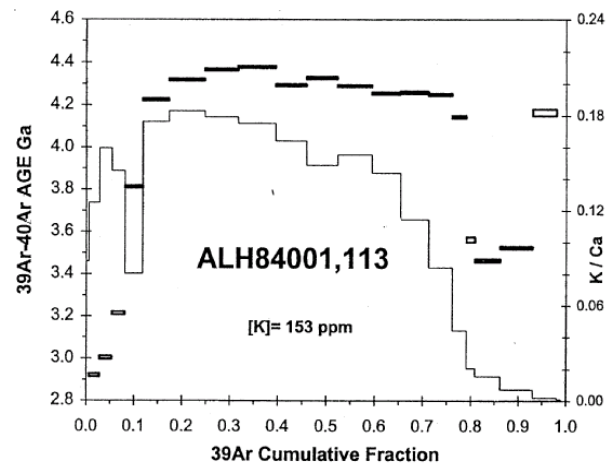


**Figure 10:** REE patterns for samples of the “crushed zone” compared with other subsamples of ALH84001. This is figure 7 from Gleason *et al.* (1997).

Jagoutz *et al.* (1994) found that Sm-Nd isotope systematics for mineral separates fit a 4.56 b.y. isochron (figure 13). Nyquist *et al.* (1995) also found that both Rb-Sr and Sm-Nd isotope systems fit 4.56 b.y. isochrons (figures 14 and 15), but that a Sm-Nd isochron defined by a “cleaned” pyroxene separate and several “whole rock” samples gave an age of  $4.50 \pm 0.13$  b.y. Miura *et al.* (1995) also reported an old age of 3 - 4 b.y. by K-Ar. Murty *et al.* (1995) calculated 3.74 b.y. Wadhwa and Lugmair (1996) reported an age based on Rb-Sr isochron through bulk rock and pyroxene separates of  $3.84 \pm 0.05$  b.y. Terada *et al.* (2003) were able to date the phosphates at about  $4018 \pm 81$  m.y. by the U/Pb ion microprobe technique and suggest that this dates a major shock metamorphism event. Finally, Lapen *et*



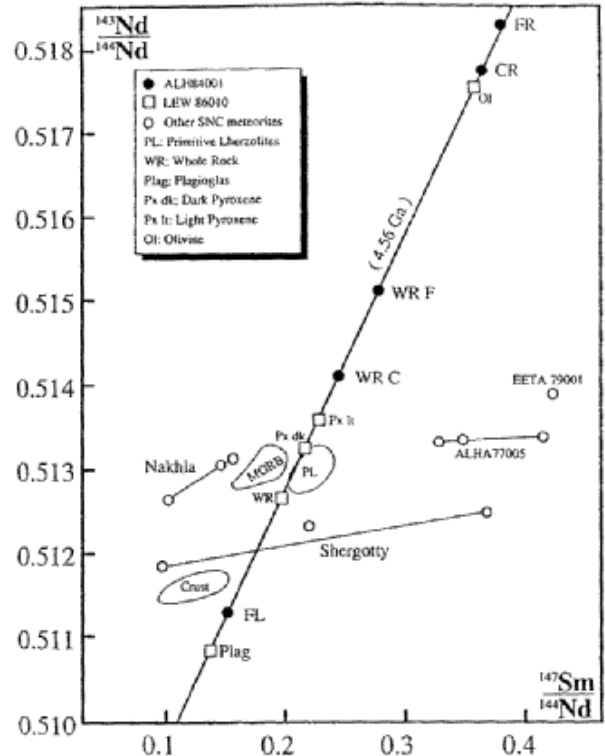
**Figure 11:** Ar plateau diagram for ALH84001,100. While a simple plateau age is 4.1 to 4.2 Ga, the “best overall age is obtained from the total argon released over 400 C”, giving an age of 3.9 to 4.1 Ga. This is figure 2 from Ash *et al.* (1996).



**Figure 12:** Ar release pattern for ALH84001,113. This is figure 6 from Bogard and Garrison (1999).

*al.* (2010) have dated ALH84001 by the Lu-Hf chronometer as  $4091 \pm 30$  m.y. (figure 18).

To add to the confusion, Foley *et al.* (2005) and Wadhwa and Borg (2006) have found “evolved” initial  $^{142}\text{Nd}$  and  $^{182}\text{W}$  isotope ratios – at the time of 4.5 b.y. – indicating that the Martain mantle source already existed that early (figure 19). A negative  $^{92}\text{Zr}$  anomaly in ALH84001,



**Figure 13:** Sm-Nd isochron diagram for mineral separates and whole rock samples from Martian meteorites including ALH84001. This is figure 3 from an abstract by Jagoutz *et al.* (1994).

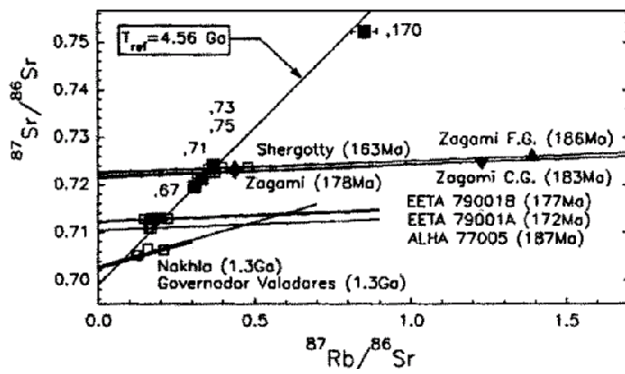


Figure 14: Rb-Sr isochron diagram for mineral separates and whole rock samples from Martian meteorites including ALH84001. This is figure 1 from an abstract by Nyquist *et al.* (1995).

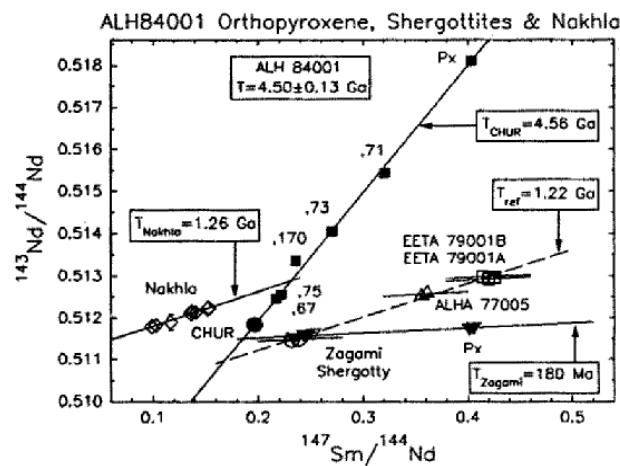


Figure 15: Sm-Nd isochron diagram for mineral separates and whole rock samples from Martian meteorites including ALH84001. This is figure 2 from an abstract by Nyquist *et al.* (1995).

also indicates an extremely early depleted trace-element (Nb) reservoir on Mars (Münker *et al.* 2001). Clearly, more work is needed to be able to interpret these preliminary results.

Wadhwa and Lugmair (1996) reported an “age of formation” of the carbonates in ALH84001 as  $1.39 \pm 0.1$  b.y., based on Rb-Sr analyses of carbonate and maskelynite. Preliminary analyses by laser probe  $^{39}\text{Ar}/^{40}\text{Ar}$  of a single large carbonate/maskelynite grain gave an age of 3.6 b.y. (Knott *et al.* 1995). However, Borg *et al.* (1999) dated carbonate leachates by Rb-Sr at  $3.90 \pm 0.04$  b.y. and U-Th-Pb at  $4.04 \pm 0.10$  b.y. (figures 16, 17).

Note: See Nyquist *et al.* (2001) for a comprehensive discussion of the ages of Martian meteorites,

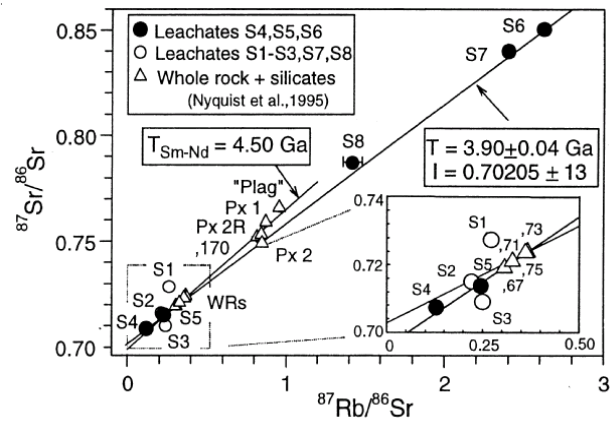


Figure 16: Rb-Sr isochron diagram of ALH84001 leachates. This is figure 2 of Borg *et al.* (1999).

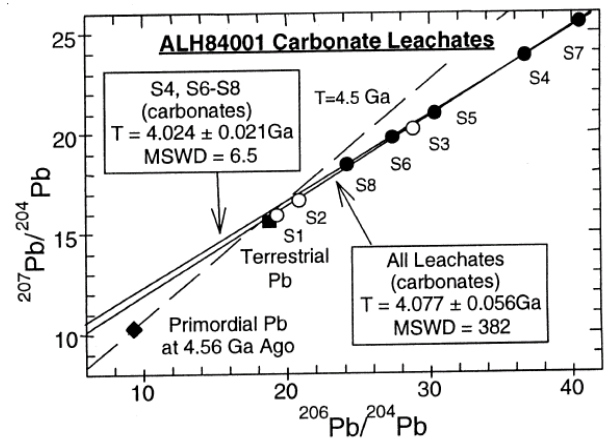


Figure 17: Pb-Pb isochron diagram of ALH84001 leachates. This is figure 3 of Borg *et al.* (1999).

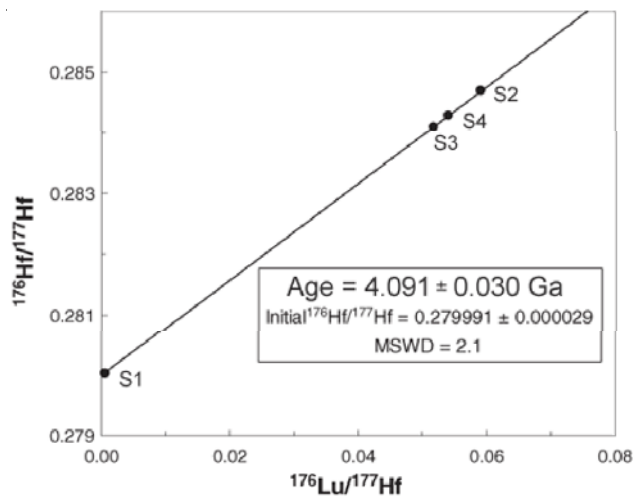
including use of a consistent set of decay constants.

### Cosmogenic Isotopes and Exposure Ages

Using  $^{14}\text{C}$ , Jull *et al.* (1989) originally determined the terrestrial age for ALH84001 as  $11.3 \pm 1.0$  thousand years, but later revised it to  $6.5 \pm 1.3$  thousand years (Jull *et al.* 1994a). Nishiizumi *et al.* (1994) also reported  $6.5 \pm 1.0$  thousand years by  $^{14}\text{C}$ . Finally, after leaching experiments to separate carbon components, Jull *et al.* (1995) again recalculated the  $^{14}\text{C}$  age as  $\sim 13$  thousand years.

From cosmic-ray produced  $^3\text{He}$ ,  $^{21}\text{Ne}$  and  $^{38}\text{Ar}$ , Eugster (1994) and Eugster *et al.* (1996, 1997) derived a cosmic-ray exposure age for ALH84001 of 15 m.y. Miura *et al.* (1995) reported a cosmic ray exposure age of 14.5 m.y.; Murty *et al.* (1995) measured the  $^{21}\text{Ne}$  exposure age as 16.4 m.y.; Swindle *et al.* (1995b) determined 15.8 m.y. and Garrison and Bogard (1997) measured 14.1 m.y. Bogard (1995) calculated an exposure age





**Figure 18:** Lu-Hf internal mineral isochron for ALH84001 (Lapen *et al.* 2010).

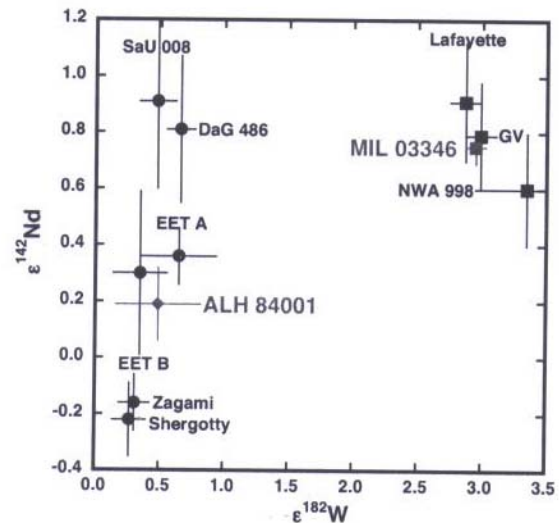
of 16 m.y. from  $^{21}\text{Ne}$  data and 18 m.y. from  $^{38}\text{Ar}$  data and Terribilini *et al.* (2000) determined 15.8 m.y. by  $^{81}\text{Kr}$  and 15.5 m.y. by  $^{21}\text{Ne}$ . Nyquist *et al.* (2001) take an average and get  $15.0 \pm 0.8$  m.y. Finally, Eugster *et al.* (2002) determined  $15.4 \pm 5.0$  m.y. using the  $^{81}\text{Kr}$  technique.

Score and Mittlefehldt (1993) reported the  $^{26}\text{Al}$  activity to be  $61 \pm 2$  dpm/kg. Nishiizumi *et al.* (1994) studied the  $^{10}\text{Be}$  and  $^{36}\text{Cl}$  as a function of depth and concluded that  $\sim 3$  cm was lost to ablation. Schnabel *et al.* (2001) determined activities for  $^{10}\text{Be}$ ,  $^{26}\text{Al}$  and  $^{53}\text{Mn}$  as 21.3, 70 and 379 dpm/kg respectively and adopt a radius of 25 cm, and a depth of 6 cm. Bastian *et al.* (2003) determined activities for  $^{10}\text{Be}$ ,  $^{26}\text{Al}$  and  $^{53}\text{Mn}$  as 23.1, 72.6 and 270.7 dpm/kg (Fe) respectively. Eugster *et al.* (2002) also estimate a minimum radius of  $24 \pm 2$  cm using  $^{80}\text{Kr}$  produced from Br. By determining cosmic ray tracks, Goswami *et al.* (1997) reported that  $\sim 5$  cm was ablated.

According to Krähenbühl *et al.* (1998), the amount of accumulated F on the surface of ALH84001 can be used to limit the time of exposure to contamination on the top of the ice to less than  $\sim 500$  years.

### Other Isotopes

Oxygen isotopes, similar to those of SNC meteorites, were reported by Clayton (1993b), Clayton and Mayeda (1996), Franchi *et al.* (1999) and Wiechert *et al.* (2001) (figure I-2). Romanek *et al.* (1996a) reported oxygen isotopes for maskelynite in ALH84001. Valley *et al.* (1997a, b), Leshin *et al.* (1997), Gilmour *et al.* (1997a,



**Figure 19:** Initial  $^{142}\text{Nd}$  and  $^{182}\text{W}$  for Martian meteorites (data from various sources, see Wadhwa and Borg 2006).

b), Saxton *et al.* (1997), Farquhar *et al.* (1998) and Eiler *et al.* (1998) have all found that oxygen isotopes in the carbonates in ALH84001 are enriched in  $^{18}\text{O}$  and strongly zoned from core to rim, but these authors do not agree on the interpretation of the cause of this zoning. Baker *et al.* (1998) have reported the  $\delta^{18}\text{O}$  for water released during heating steps.

Carbon and oxygen isotopes in  $\text{CO}_2$  released by acid dissolution from carbonates have been studied by Romanek *et al.* (1994a) who found that  $\delta^{13}\text{C}$  was  $+40$  ‰ and  $\delta^{18}\text{O}$  was  $+20$  ‰. During differential acid-etching of the carbonates in ALH84001, Jull *et al.* (1995, 1996b, 1997, 1998) found that the initial  $\text{CO}_2$  released contained  $^{14}\text{C}$  enrichment associated with light  $^{13}\text{C}$  (figure I-14), but that the  $\text{CO}_2$  released during later steps was low in  $^{14}\text{C}$  and had the highest  $\delta^{13}\text{C}$  ( $+45$  ‰). Grady *et al.* (1994a) and Leshin *et al.* (1996c) also reported heavy  $\delta^{13}\text{C}$  and  $\delta^{18}\text{O}$  for  $\text{CO}_2$  released from ALH84001. Apparently the major carbonate phase in ALH84001 formed from the Martian hydrosphere/atmosphere (Jull *et al.* 1996b, 1997a).

The D/H ratio of water released by heating steps was studied by Watson *et al.* (1994c), Leshin *et al.* (1996c) and Eiler *et al.* (2001). They found  $\delta\text{D}$  for the highest temperature step to be  $+783$  ‰, comparable to the values measured for the nakhlites (figure II-11) - see Nakhla. This is less than the extreme  $\delta\text{D}$  found in the shergottites. Boctor *et al.* (1998a, b, 1999) have also reported  $\delta\text{D} = +200$  ‰ to  $+500$  ‰ for

phosphates and carbonates in ALH84001. Sugiura and Hoshino (2000) found  $\delta D = +2000$  ‰ in the carbonates by SIMS analysis.

Miura and Sugiura (1994), Murty *et al.* (1995) and Grady *et al.* (1996a, 1998) reported heavy nitrogen isotopes released in high temperature steps ( $\delta^{15}N = 143$  ‰). Miura and Sugiura (2000) found nitrogen with  $\delta^{15}N = 418 \pm 44$  ‰ above 800 °C. Murty and Mohapatra (1997) reported a component with  $\delta^{15}N > 47$  ‰. Murty *et al.* (1995) speculated that the lightest  $\delta^{15}N$  value of  $-21$  ‰ might be the Martian indigenous component. However, Mathew *et al.* (1998) found  $\delta^{15}N = -30$  ‰ in the low temperature release and concluded that the nitrogen released from the carbonate had not equilibrated with the Martian atmosphere ( $\delta^{15}N = 620$  ‰).

Miura *et al.* (1995), Murty *et al.* (1995), Murty and Mohapatra (1997) and Swindle *et al.* (1995b) found that ALH84001 contains high  $^{129}Xe$ . However, Ash *et al.* (1996) found little evidence for the presence of a significant Martian atmosphere component in their piece. Gilmour *et al.* (1996) found that the excess  $^{129}Xe$  was in the orthopyroxene and not in the carbonate.

Mathew and Marti (2001) found that light nitrogen is associated with the unfractionated “primitive” Xe component (as is also the case in Chassigny). Bogard and Garrison (1997) and Mathew and Marti (2001) have also determined the Ar, Xe and Kr systematics of this “primitive” gas component.

Lugmair *et al.* (1996) and Lugmair and Shukolyukov (1998) studied the  $^{53}Mn$  -  $^{53}Cr$  systematics in mineral separates (chromite, pyroxene and bulk silicate) of ALH84001 and found that all splits gave the same  $^{53}Cr/^{52}Cr$  excess of  $0.22 \pm 0.10$  epsilon, similar to data from Shergotty (figure I-6). Hidaka *et al.* (2001) discovered small variations in Sm and Gd isotopic ratios sensitive to neutron capture.

Shearer *et al.* (1996a, 1997) and Greenwood *et al.* (1997a, b, 2000, 2001) determined the isotopic composition of S in ALH84001 by the ion microprobe technique (figure 19). They found greater fractionation of  $^{34}S/^{32}S$  in sulfide phases in ALH84001 “*than for any other meteorite*”. However, most of the pyrite grains studied by Shearer *et al.* (1996b, 1997) and/or Greenwood *et al.* (1997 a, b) were large grains (10-20 microns), and not the extremely fine-grained sulfides

reported by D. McKay *et al.* (1996) (pyrrhotite/greigite?) in the black outer rims of the carbonates. Boctor *et al.* (1998) have also reported  $\delta S$  for pyrite in ALH84001.

### **Carbonate “Rosettes”**

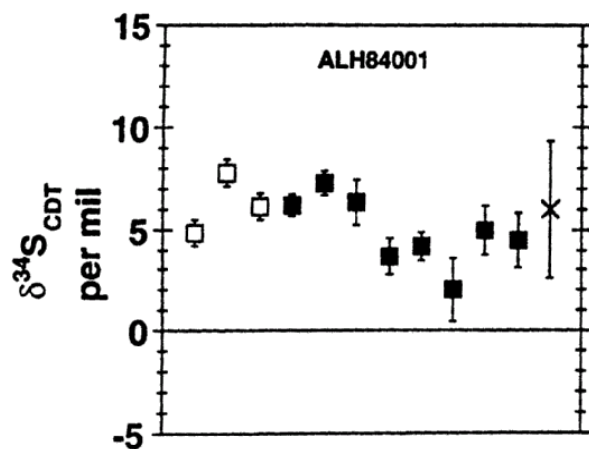
Mason *et al.* (1992), Mittlefehldt (1994a) and Treiman (1995b) originally reported clusters of orange carbonates in thin sections of ALH84001 (figure 20, *also see numerous color pictures in Scott et al. 1998*). These special features have variously been referred to as “orange spheroids” by Romanek *et al.* (1995), “carbonate globules” by D. McKay *et al.* (1996) and Scott *et al.* (1997), “rosettes” by Harvey and McSween (1995, 1996), “rounded zoned blebs” by Mittlefehldt (1997), “carbonate disks” by Scott *et al.* (1998) and “disk-shaped concretions” by Valley *et al.* (1997). Scott *et al.* (1998) argue that all forms of carbonate in ALH84001 have the same origin, because they all have similar chemical zonation.

“Carbonate Rosettes” are only a very minor phase assemblage of ALH84001 (~0.5%). They occur as small (100 to 250 micron) concentric spheroids, in the interior of the igneous portions of the rock (Mittlefehldt 1994a; Treiman 1995b) and along natural fractures (D. McKay *et al.* 1996) where they are apparently “pancake-like” (Romanek *et al.* 1995). Typically, these carbonate “rosettes” are zoned, from Ca- and Fe-rich to Mg-rich (Harvey and McSween 1995, 1996). They are also apparently zoned in Mn/Fe (Treiman 1995b; D. McKay *et al.* 1996). Perhaps the best picture of a complete “rosette” is figure 1g of Scott *et al.* (1998).

Typically, each “rosette” has a fine-zoned, black-white-black, outer rim — *as in an “Oreo cookie.”* The black outer zones (~1-5 microns) are Fe- and S-rich, while the white sandwich zone is nearly pure magnesite (Mittlefehldt 1994a; Treiman 1995b; Thomas *et al.* 1996; D. McKay *et al.* 1996; Scott *et al.* 1998). Magnesite has crystal faces projecting outward (Romanek *et al.* 1994; Treiman and Romanek 1998; G. McKay and Lofgren 1997). The Fe-rich zones contain fine, single-domain, magnetite and sulfide (Thomas *et al.* 1996; Golden *et al.* 2004). In some cases, an additional zone of pure magnesite is found beyond the outer black zone. So, optically, the best preserved “rosettes” zone from dark orange to light orange, black, white, black, white. (*however, see footnote*)

Within one of the granular bands, Treiman (1995b)



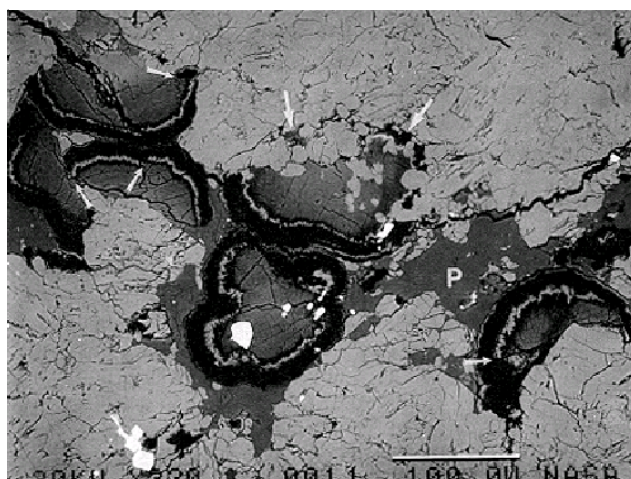


**Figure 19:** Sulfur isotopic analysis of sulfides in ALH84001. Open symbols are data from Shearer *et al.* (1996), black squares are data from Greenwood *et al.* (1997) and X is for the black rims of the carbonates. This is figure 2 from Greenwood *et al.*

reported on a concentric, zoned carbonate patch, where the carbonate was found as a 3-dimensional, interconnecting, filling within a mesh of crushed orthopyroxene grains. The same compositional zoning is present in this patch as in the case of other “rosettes.” In other cases, the carbonate “rosettes” appear to be “growing” free on the surfaces in the freshly-broken, but pre-existing, natural fractures of the rock (D. McKay *et al.* 1996). Some of the carbonate globules even appear “pancake-like”, suggesting that the carbonates formed in the restricted width of a thin fracture (Romanek *et al.* 1995; D. McKay *et al.* 1996; Scott *et al.* 1998).

Romanek *et al.* (1995a) and Thomas *et al.* (1996) studied these fine-grained carbonate lithologies and observed that magnetite grains in the dark outer band showed “similarities to those formed as a by-product of certain biological activities.” Thomas *et al.* (1995) and D. McKay *et al.* (1996) have reported PAHs (polycyclic aromatic hydrocarbons) associated with these carbonate “rosettes.” D. McKay *et al.* argued that “the carbonate globules are similar in texture and size to some terrestrial bacterially induced carbonate precipitates” (see section on “Biogenic Hypothesis”). See alternate interpretation in section on “Abiotic (Inorganic) Hypothesis”.

The temperature of formation of these carbonate “rosettes” has been a focus of discussion. On the basis of major element analysis of the carbonates, and equilibrium phase relationship of carbonates, Mittlefehldt



**Figure 20:** Back-scattered-electron photograph of thin section of ALH84001 illustrating several zoned carbonate globules in cross section. This figure clearly shows that the carbonate globules are replacing the maskelynite/plagioclase (P) in the sample. The bright, roughly circular features are Fe-rich carbonate zones containing magnetite and sulfide. This zone is surrounded by the Mg-rich carbonate (dark in BSE) and a second, thin, bright Fe-rich zone. The scale bar is 100 microns. This is figure 4 from Treiman (1994b).

(1994a) and Harvey and McSween (1995, 1996) concluded the temperature of formation was on the order of 700°C. On the other hand, Romanek *et al.* (1995a), D. McKay *et al.* (1996) and Valley *et al.* (1997) have argued that oxygen isotope data indicate carbonate formation between 0 and 80°C. Valley *et al.* (1997) and Saxton *et al.* (1997) have refuted the high temperature formation of carbonate with oxygen isotope data collected by ion microprobe. However, Leshin *et al.* (1997) infer that the oxygen isotopic data do not provide unequivocal evidence for low temperature. Browning and Bourcier (1997) argued that calcite, magnesite and pyrrhotite can coexist over a wide range of conditions. In fact, the extensive chemical zoning and the complex fine-grained mineral assemblage of the outer rims clearly indicates that these “rosettes” did not form in an equilibrium environment (Romanek *et al.* 1995). Kirschvink *et al.* (1997) have used magnetic data to also show that their small pyroxene sample could not have been exposed to high temperature during the secondary event that produced the carbonate. Theis *et al.* (2008) determined the isotopic composition of iron in carbonates and concluded a temperature of origin of 83 ± 67 °C.

## Summary of Isotopic Results on Carbonate “Rosettes” in ALH84001

	delta <sup>13</sup> C	delta <sup>18</sup> O	Delta <sup>17</sup> O ‰ <sup>14</sup> C
<b>magnesite rims</b>			
Valley <i>et al.</i> 1997a		20.6 ± 1.3 ‰	
Saxton <i>et al.</i> 1997		20-22 ‰	
Niles <i>et al.</i> 2005		46 – 65 ‰	
<b>cores</b>			
Valley <i>et al.</i> 1997a	46 ± 8 ‰	16.7 ± 1.2 ‰	
		11.5 ± 2.0 ‰	
Saxton <i>et al.</i> 1997		10 - 22 ‰	
Leshin <i>et al.</i> 1997		6 - 22 ‰	
Farquhar <i>et al.</i> 1998		18.3 ± 0.4 ‰	0.8 ‰
Niles <i>et al.</i> 2005	28 – 46 ‰		
<b>bulk (acid dissolution)</b>			
Jull <i>et al.</i> 1997a	32 - 40 ‰	10 - 17 ‰	high activity
Grady <i>et al.</i> 1994a	40.1 ‰		
other authors*	36 ± 10 ‰	17.5 ± 2.7 ‰	
<b>bulk (stepped combustion)</b>			
Jull <i>et al.</i> 1998 (low temp.)	-22 - -33 ‰		37-52 ‰ modern
Jull <i>et al.</i> 1998 (high temp.)	32 - 40 ‰		<3 ‰ modern

\* averages quoted by Valley *et al.*

**Caution: this table is only a summary and the reader is referred to original papers**

The nature of the metasomatism (or alteration) during the carbonate deposition (or replacement) has been another topic of discussion. Wadhwa and Crozaz (1994b, 1995b) introduced the idea of two stages of “infiltration metasomatizing fluids”. Gleason *et al.* (1997) interpret the petrographic textures and chemical compositions to be consistent with “an inorganic origin for the carbonate, involving dissolution-replacement reactions between CO<sub>2</sub>-charged fluids and feldspathic glass” and “clearly postdated processes that last redistributed the REE in the meteorite”. Kring *et al.* (1998) find that “the carbonate globules were produced at the expense of maskelynite in a dissolution-precipitation reaction that involved a carbonic fluid”. Scott *et al.* 1997, 1998 propose a high-temperature, CO<sub>2</sub>-rich fluid derived by impact. G. McKay *et al.* (1998) have been so bold as to propose that the very fine, set of “web-like” veins that they observed, was “precipitated from a fluid that permeated the granulated feldspathic zones” and that the various crack filling minerals in ALH84001 were deposited from “fluids of varying compositions” which “moved freely, leaving behind a variety of minerals as evidence of their passage.”

Griffith and Shock (1995, 1997) have provided a useful discussion of hydrothermal carbonate formation on Mars based on theoretical calculations and their experience with Icelandic basalts. See also the discussion of alteration in Treiman (1995b), Wentworth and Gooding (1995) and Harvey and McSween (1995, 1996). McSween and Harvey (1998) and Warren (1998) explained formation of carbonates as low-temperature precipitates during flood/evaporation of salty water. Scott (1999) and Warren (1999) have further discussed the flood/evaporation model.

Two, different, shock-melting models for the origin for the carbonates in ALH84001 have been proposed (Harvey and McSween 1996; Scott *et al.* 1997, 1998). These models have the apparent advantage of not requiring fluids flowing through the rock, but they do imply a high temperature origin for the carbonates (Scott *et al.* 1998). For the case of a shock origin of carbonate features, a pre-existing carbonate is required.

Borg *et al.* (1999) dated the carbonates by carefully leaching the samples and measuring the leachates (Rb-Sr at 3.90 ± 0.04 b.y. and U-Th-Pb at 4.04 ± 0.10 b.y.).

The carbonates may be 500-600 m.y. younger than the initial crystallization of the rock (*see section on "Radiogenic Isotopes"*). However, leaching may have also attacked phases other than carbonate and/or there may be more than one generation of carbonate. Note that Wadhwa and Lugmair (1996) reported another age for the carbonates (1.39 b.y.) – *see section on Radiogenic Isotopes*.

Eiler *et al.* (1998) have studied the correlation of oxygen isotopes with variation in major element composition of the carbonates (zoning). Farquhar *et al.* (1998) showed that the carbonates in ALH84001 contained an atmospheric component enriched in distinctive non-mass-fractionated oxygen.

### Other Experiments

Bell (2007) has experimentally studied the shock origin of magnetite from siderite. A shock pressure of 49 GPa, with associated thermal pulse of >470 deg. C, can produce magnetite grains with size and shapes seen in ALH84001.

Golden *et al.* (2000, 2001) reported experimental evidence that zoned Mg-Fe-Ca carbonates, magnetite, and Fe sulfides (as found in ALH84001) may have formed by "simple, inorganic processes", by rapid precipitation from aqueous solution at low temperature, followed by brief heating to 470°C. Vecht and Ireland (2000) have also shown experimentally that Ca-carbonate structures similar to those in ALH84001 can be formed in a non-biotic environment. However, the carbonates in ALH84001 are primarily Mg and Fe-rich carbonates.

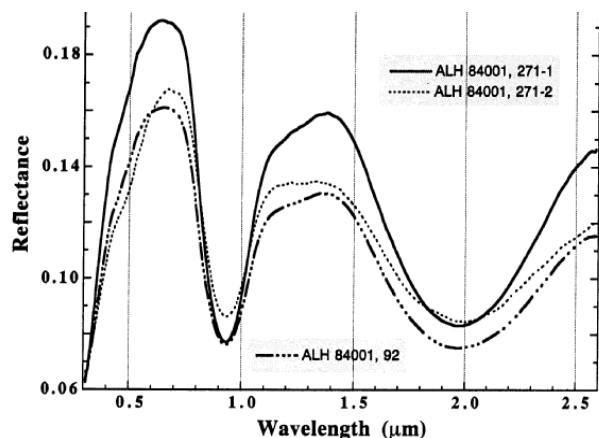


Figure 21a: Visible to near-IR reflectance spectra of ALH84001, showing absorption bands due to pyroxene. This is figure 1 from Bishop *et al.* (1998).

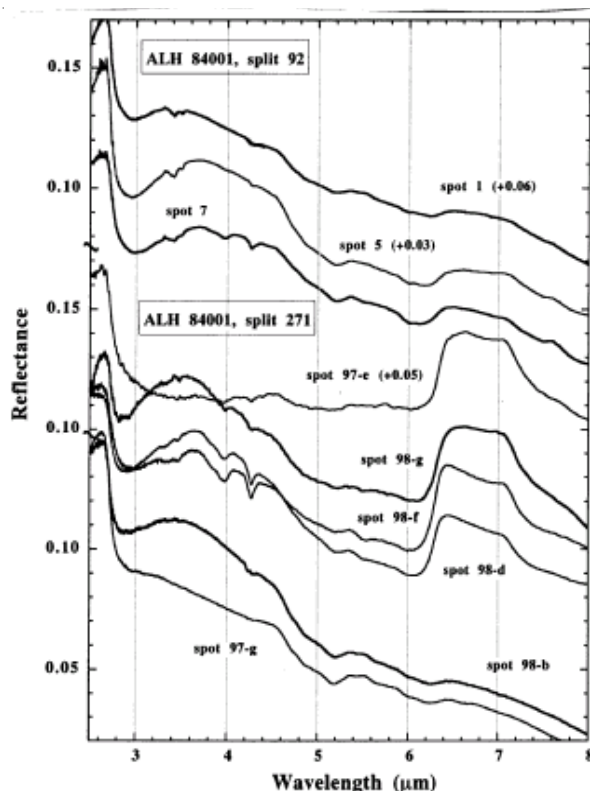


Figure 21b: Infrared reflectance spectra of chips of ALH84001. This is figure 2 of Bishop *et al.* (1998).

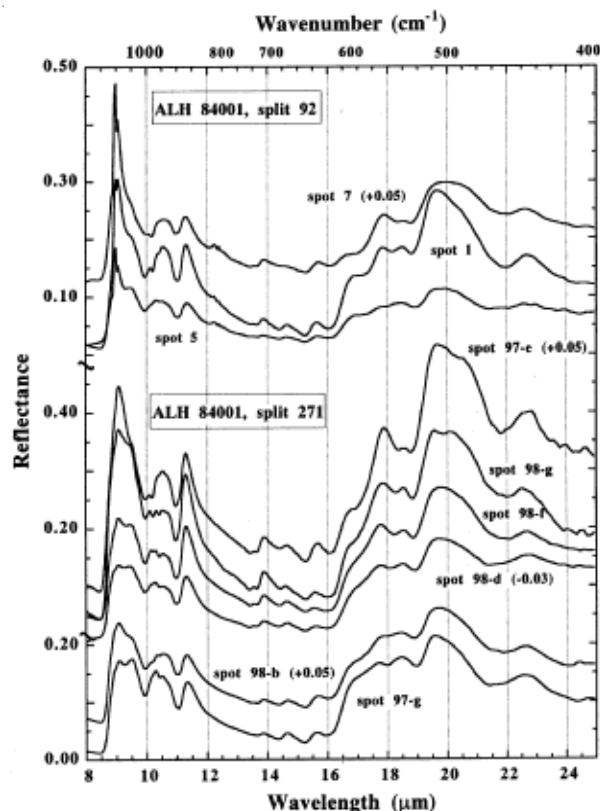
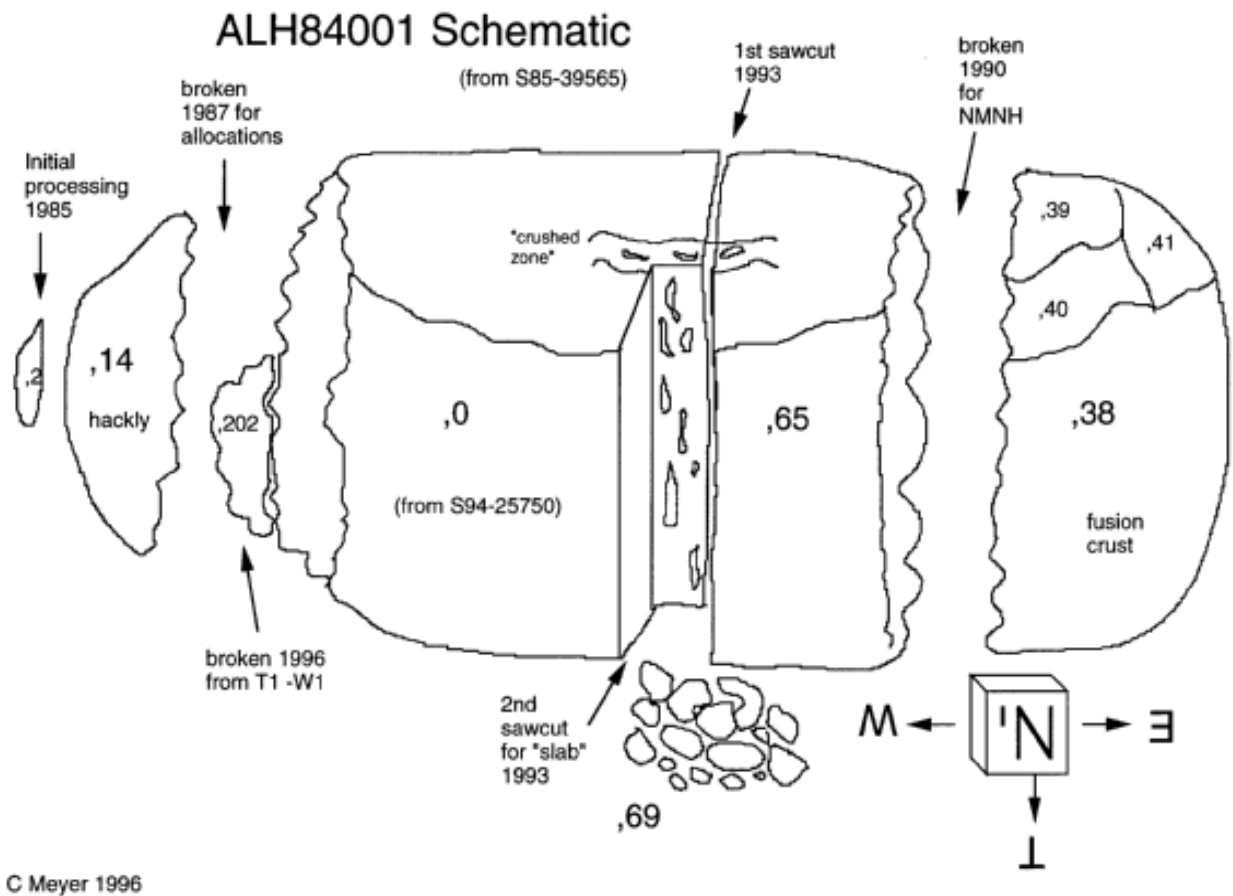


Figure 21c: Infrared spectra of chips of ALH84001 (cont.). Figure 3 of Bishop *et al.* (1998).





**Figure 22a:** Photograph of ALH84001,1 and ,65 after the sample was sawn in 1994. The slab fell apart during cutting. Cube is 1 cm. (NASA #S94-25750)



C Meyer 1996

**Figure 22b:** Schematic drawing illustrating breaking and sawing of ALH84001 up to 1996. More detailed information is kept in the "data pack" maintained by the Curator's Office at JSC.

Natural thermoluminescence was reported as  $1.3 \pm 0.1$  krad (Score and Mittlefehldt 1993). Protheroe and Sterling (1998, 2000) have studied cathodoluminescence of phases in ALH84001.

Bishop *et al.* (1994), Bishop and Pieters (1996) and Bishop *et al.* (1998a,b) have measured the infrared reflectance spectra from ALH84001 (figure 21 a,b,c).

Sinha and Goswami (1994) and Goswami *et al.* (1997) studied nuclear tracks from numerous splits of ALH84001 and concluded that it lost 5 cm on all sides due to ablation in the Earth's atmosphere.

Kirschvink *et al.* (1997) found that “two adjacent grains of pyroxene each possessed a stable natural remanent magnetization, implying that Mars had a substantial magnetic field when the grains cooled.” Weiss *et al.* (2000) studied the direction of magnetization of small grains “*in-situ*”, in carefully mapped samples of ALH84001 and inferred that the magnetization was due to magnetite and pyrrhotite in carbonate and that the direction of magnetization was related to the fractures. Heating the meteorite chips to only 40°C reduces the intensity of some magnetic features. They concluded that the meteorite was not heated above this temperature as it was lofted off of Mars. Collinson (1997) was not able to determine which mineral was responsible for the recorded magnetism. Anstetter and Fuller (2001) found that the dominant magnetic phase is magnetite, but that another magnetic phase may also be present. Weiss *et al.* (2001, 2002a,b) reported additional, microscopic, studies of magnetization in ALH84001. They conclude that the magnetization was acquired prior to 3.9 Ga and that ALH84001 has not been heated above the Curie point (580°C?) since that time!

Becker *et al.* (1997) and Clemett *et al.* (1998) have performed experiments to show whether polycyclic aromatic hydrocarbons (naphthalene) can be selectively adsorbed and concentrated on carbonates.

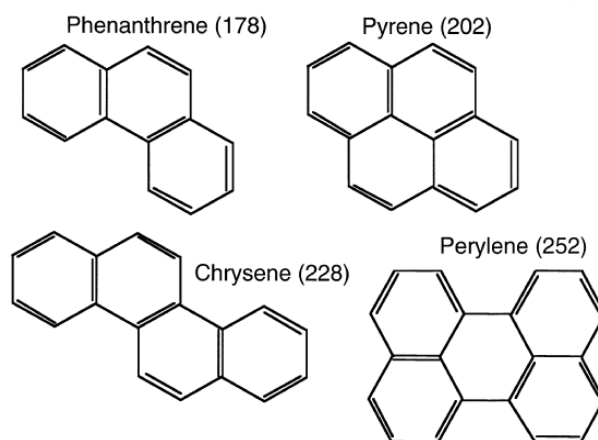
The study of ALH84001 can be expected to lead to studies of some selected terrestrial rocks with apparently similar features. For example, Treiman *et al.* (1998) have found similarities of carbonates in mantle xenoliths and their host basalts from Spitsbergen with some of the features in ALH84001.

Jones and Schwandt (1998) and Koziol (1999) performed experiments related to the high pressure, high temperature stability of siderite. Bell *et al.* (1998) and Schwandt *et al.* (1998) have attempted to determine whether shock melting of carbonate can occur. Diffusion experiments of cations in carbonates, as reported by Fishler and Cygan (1998) and Kent *et al.* (2001), constrain the temperature of formation, and of later reheating, of fine-grained zonation of carbonates in ALH84001.

## Organics

The distribution, nature and origin of organic compounds within ALH84001 is controversial (Flynn *et al.* 1998; Becker *et al.* 1999; Steele *et al.* (2007, 2008). Polycyclic aromatic hydrocarbons (PAHs), macromolecular carbon (MMC) and terrestrial contamination are involved – in addition to FeCO<sub>3</sub> and perhaps poorly defined “graphite” (Hochleitner *et al.* 2004).

Grady *et al.* (1994a) reported 257.2 ppm “organics” released at a temperature below 450°C. They found these “organics” to have  $\delta^{13}\text{C} = -21.5\text{‰}$ . This was confirmed by Jull *et al.* (1998) who find that at least 80% of the combustible “organic” material in ALH84001 is terrestrial contamination (*i.e.* contains <sup>14</sup>C). Thomas *et al.* (1995) and D. McKay *et al.* (1996) reported unique polycyclic aromatic hydrocarbons (PAHs) located on fresh fractures in ALH84001 that also contain the carbonate “rosettes.” McKay *et al.*



**Figure 23:** Some of the polycyclic aromatic hydrocarbon compounds reported by McKay *et al.* (1996) in carbonate areas of ALH84001. The major peak was mass 228 (see mass spectrum, figure 1, in McKay *et al.*).

(1996) give evidence that these PAHs are not like any known terrestrial or meteoritic contamination (figure 23). However, only one mass spectrum was presented (figure 1 in McKay *et al.* 1996). Becker *et al.* (1999) found two organic carbon components: 1) organic contamination (including PAHs) associated with the carbonates with  $\delta^{13}\text{C} = -26\text{‰}$ , and 2) kerogen-like organics with  $\delta^{13}\text{C} = -15\text{‰}$  from the bulk sample (which they interpret as meteoritic). Becker *et al.* reported that the PAHs in ALH84001 carbonates were similar to those they found in EETA79001 “white druse” (Becker *et al.* 1997). Using TOF-SIMS, Stephan *et al.* (1998a, b, 1999, 2000) studied PAHs on fractured surfaces where carbonates are located in ALH84001 (figure 28). This technique has higher spatial resolution than that used by McKay *et al.* (1996) allowing Stephan *et al.* to conclude that the PAHs were not associated with the carbonates, as had been asserted by McKay *et al.* (Some of the organics seen by Stephan *et al.* may be contamination, because they also see Pb with terrestrial isotopic composition, and they were originally working on thin sections prepared with and impregnated with epoxy.) On the other hand, using STXM and FTIR techniques with narrow spatial resolution, Flynn *et al.* (1998a,b) reported close spatial association of organics with carbonate globules and rims in ALH84001. Zolotov and Shock (2000) calculate that extraterrestrial PAHs (if they are present) could have formed metastably from CO, CO<sub>2</sub> and H<sub>2</sub> below approximately 300°C during rapid cooling of trapped magmatic or impact-generated gases.

Bada *et al.* (1998) detected trace amounts of amino acids (glycine, serine and alanine) in the carbonate component of ALH84001 using high performance liquid chromatography. The detected alanine consists primarily of the L-enantiomer; a strong indication that the amino acids found in this rock are the result of terrestrial contamination. (Presumably, amino acids from Mars would be so old, and highly shocked, that they should be both right and left handed).

Jull *et al.* (1998) provided isotopic evidence (see table above) for a terrestrial source of most of the organic compounds found in ALH84001 (as well as in EETA79001). They also reported a hint of a small pre-terrestrial carbon component of unknown origin (possibly the residual acid-insoluble or refractory organic phase).

### **The Biogenic Hypothesis**

In their original paper on ALH84001, D. McKay *et al.* (1996) made the following observations:

1) ALH84001 is an igneous rock from Mars “that was penetrated by a fluid along fractures and pore spaces, which then became the sites of secondary mineral formation and possible biogenic activity.”

2) the formation age for the carbonate globules “is apparently younger than the age of the igneous rock.”

3) high resolution SEM images reveal minute features “resembling terrestrial microorganisms, terrestrial biogenic carbonate structures, or microfossils.” (images can be viewed at <http://rsd.gsfc.nasa.gov/marslife>)

4) co-occurrence of both oxidized magnetite and reduced sulfide particles “that could have resulted from oxidation and reduction reactions known to be important in terrestrial microbial systems” in the outer margins of the carbonate, which appears to be in dissolution.

5) the “presence of organic matter (PAHs) associated on surfaces rich in carbonate deposits.”

D. McKay *et al.* cautiously admitted that while “none of these observations is in itself conclusive for the existence of past life,” that when considered collectively, particularly in view of their spatial association, provided “evidence for primitive life on early Mars.”

Bradley *et al.* (1997) and D. McKay *et al.* (1997) have argued about whether or not the “microfossil features” could be artifacts of the SEM techniques used and/or exsolution features exposed at mineral edges. Gibson *et al.* (1997a) reported “the ‘nanobacteria’-like features within ALH84001 range in size from 20 to 500 nanometers. The structures are spherical, elongated, and segmented in shape and several appear to be dividing.” D. McKay *et al.* (1997) and Steele *et al.* (1997) also documented the occurrence of “biofilms” within ALH84001 associated with the carbonates. Thomas-Keprta *et al.* (1999) compared fossilized bacterial features (mineralized filaments and appendages) in Columbia River Basalt with similar features in ALH84001. Benoit and Taunton (1997) searched the internal surfaces of several lunar and Martian meteorites collected in Antarctica, and processed at JSC, for features similar to the ‘nano-



fossils' reported by D. McKay *et al.* (1996). Not finding any, they concluded the features observed in the carbonates in ALH84001 "are probably not terrestrial contamination". However, Sears and Kral (1998) reported that they did find similar features in Lunar Meteorites from Antarctica.

McSween (1996) and Gibson *et al.* (2001) discuss the evidence of D. McKay *et al.* for "possible relic biogenic activity in Martian meteorite ALH84001." Other studies, for and against the "biogenic hypothesis", have been reported; including Leshin *et al.*, Bradley *et al.*, Thomas-Keprta *et al.*, Shearer *et al.*, Wright *et al.*, Gilmour *et al.*, Greenwood *et al.*, and others (all 1997). Gibson *et al.* (1997a, b, d) provided summaries of the evidence for "biogenic activity" in the carbonates in ALH84001 and Valley *et al.* (1997a, b) and Kirschvink *et al.* (1997a, b) have provided evidence of low temperature formation of the carbonates in ALH84001 - which is a necessary condition for biogenic activity. However, Cooney *et al.* (1999) found that micro-Raman band broadening in complex carbonates, amorphous silica and plagioclase glass indicates extreme shock pressure (~50 GPa) and point out that "any search for biogenic markers in ALH84001 must recognize the complex shock and thermal history of these minerals".

Thomas-Keprta *et al.* (2000 2008) have consistently maintained that the elongated prisms of magnetite found in siderite in ALH84001 are "chemically and physically identical to terrestrially, biologically-precipitated, intracellular magnetites produced by magnetotactic bacteria strain MV-1". Friedmann *et al.* (2001) identified what they interpreted as chains of magnetite like those in magnetotactic bacteria. However, Buseck *et al.* (2001) questioned both studies.

### **The Abiotic (Inorganic) Hypothesis**

Following the original critique of Anders (1996), McSween (1996) and Treiman (2003), laboratory synthesis experiments performed by Golden *et al.* (2000, 2001, 2003) indicate that the zoned carbonate globules, and associated magnetite and Fe sulfides, could have formed by precipitation from aqueous solution, followed by brief heating to 470°C. Aqueous precipitation from evaporating bicarbonate-rich solution produces the observed chemical zoning in the carbonate precipitates with enriched <sup>13</sup>C. Iron-rich carbonate is the last to form accompanied by sulfides. Subsequent heating associated with shock produces magnetite, and converts pyrite to pyrrhotite, driving off S and CO<sub>2</sub>. In localized areas, temperature is briefly high enough to form periclase from Mg-carbonate (Barber and Scott 2002). Golden *et al.* (2003) claim that all of the shapes of the controversial magnetite grains can be explained by this inorganic hypothesis.

Scott (1999) reviewed the observations of the carbonate-magnetite-sulfide assemblages in ALH84001 and concluded that they were shock decomposition products of an assemblage that originally formed from aqueous fluids. Shearer *et al.* (1999) inferred that a short shock-heating event, after the carbonate deposition, disrupted the carbonates, mobilized feldspar glass, formed minute olivine inclusions in orthopyroxene and may have formed the magnetite grains in siderite. Bell (2007) has experimentally demonstrated that magnetite can be formed by shock heating of siderite.

Steele *et al.* (2007, 2008) have shown that macromolecular carbon (MMC) deposits are associated with magnetite-carbonate features in ALH84001 and that the MMC synthesis mechanism can be abiotic in the Fe-C-O system. McCollom (2003) has also shown that some organic compounds (alkylated and hydroxylated aromatic compounds) can be generated, abiotically, by thermal decomposition of iron-rich carbonate in the presences of some moisture.

---

**Footnote:** *It is this compiler's observation, that after considerable research by various team, it now seems (in 2008) that various inorganic processes can reproduce all of the features found in ALH84001 and that there is no compelling evidence for life on Mars from this important (albeit complicated) sample.*

---

**Footnote:** *Dry sawing of a rock sample, produces considerable friction and heat. The saw marks, such as are seen in figures 5 and 6, are a clear indication that there was considerable friction during sawing of ALH84001.*

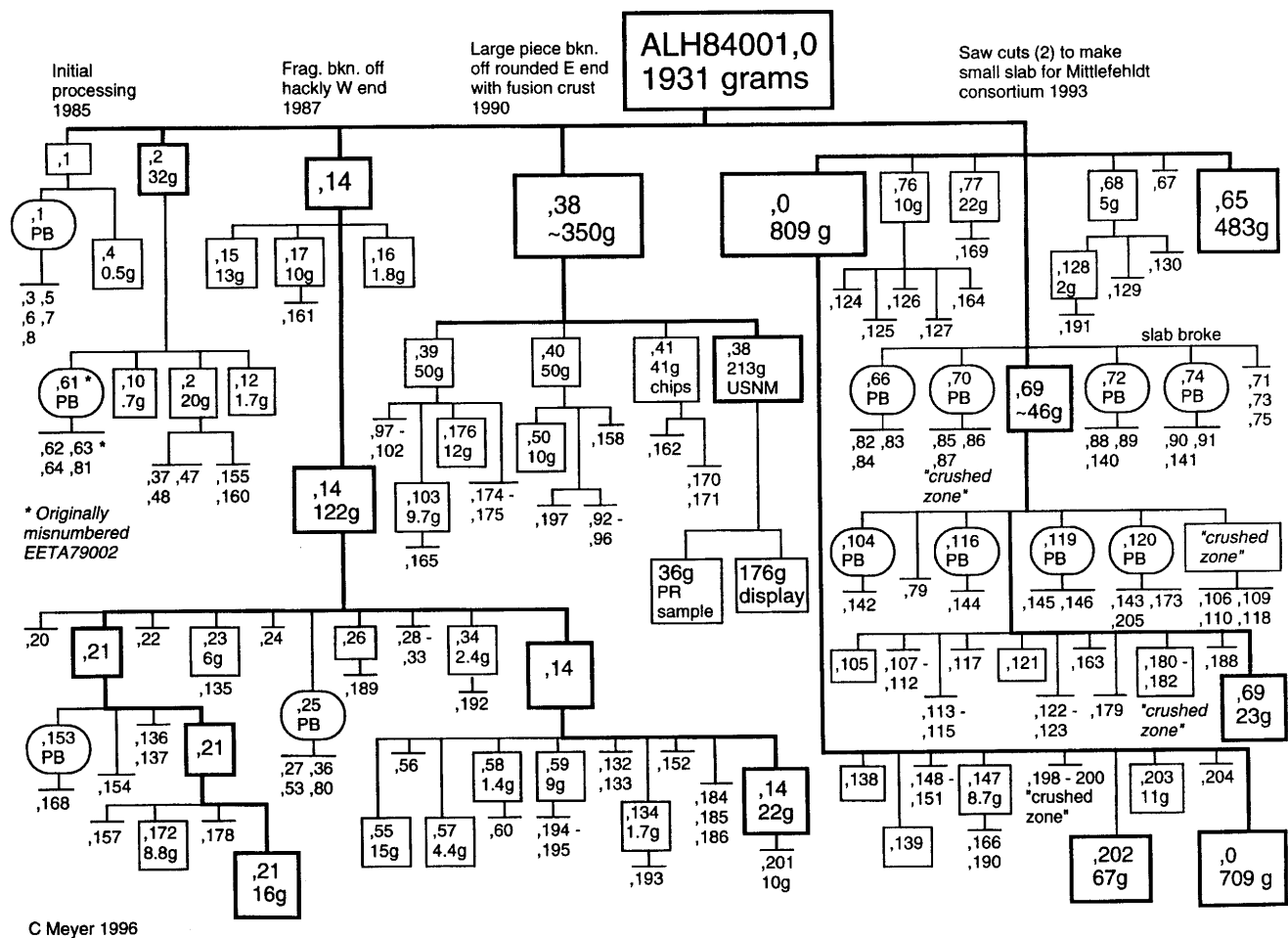


Figure 24: Geneology diagram for ALH84001 illustrating complexity of allocation and distribution up to 1996.

## Processing

The initial processing of ALH84001 (1985) was from the angular hackly end, where a piece (.2) was broken off for preliminary allocations. Additional allocations were made in 1987 from a larger piece (.14), also from this hackly end. In 1990, a large piece (.38) with intact fusion crust was split off the smooth, blocky end (with rock-splitter) for display (*as a diogenite*) at the Smithsonian (USNM). In 1994, in an attempt to saw a slab out of the middle of the main sample for a consortium study led by David Mittlefehldt, the small slab broke at a “porous band of weakness” halfway through (figure 22). The “half slab” (.69) broke into many pieces, from which the consortium allocations were made. (*see footnote*)

In August 1996, allocations of ALH84001 were suspended until NASA and NSF proposals were reviewed and a new clean processing cabinet prepared. In March 1997, a special Mars Meteorite Working

Group (M-MWG) committee considered 45 sample requests. The committee decided to preserve ALH84001,0 (about 709 grams) for future studies, but allowed disaggregation of .65 (about 483 grams) for allocation along with the smaller pieces (Marvin 1997). Scientists received this second round of allocations of ALH84001 in June-July 1997. In 1997, numerous, small, oriented samples were taken for magnetic orientation. Since 1997, allocations of ALH84001 have been ongoing.

Figures 24 and 25 attempt to diagram the complex processing for this sample. Fifty-five thin sections are derived from 14 different chips (*some were prepared with superglue for easy detachment for TEM studies*). Obviously, different scientists have been studying different portions of this rock. To partially solve this problem, 8 thin sections were used for rotation among petrographers (1 month each) during 1997-8. In fact, many scientists have had the opportunity to

# ALH84001 (continued)

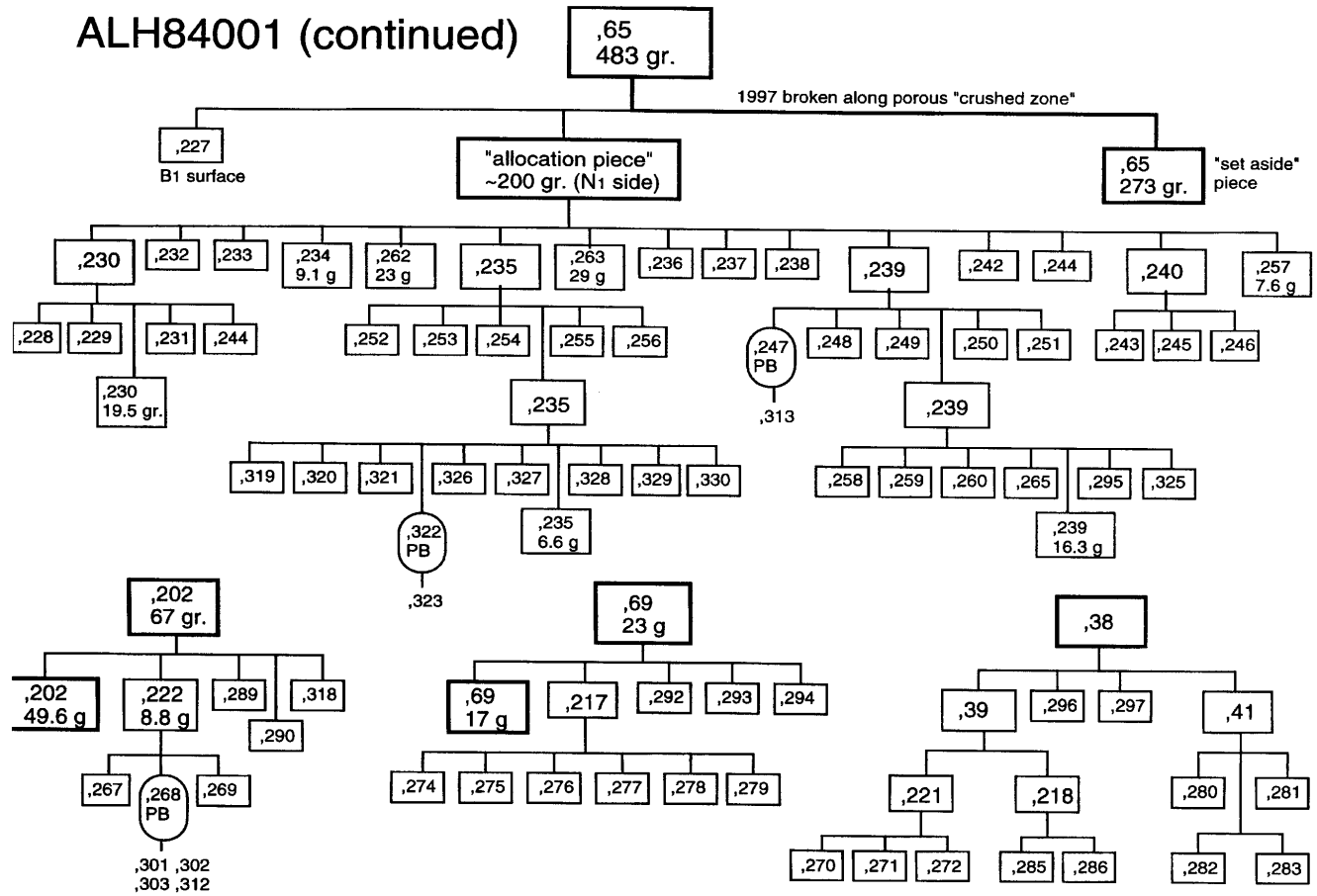


Figure 25. Extended genealogy diagram for ALH84001 (as of Jan 1998).

apply their techniques and expertise to the study of this unique sample. As of 2012, a considerable amount of this sample remains stored in dry nitrogen, awaiting further well-planned studies.

## References for ALH84001